

Modellname / Model name / Nom du modèle /
 Nome modello / Název modelu / Modelnaam / Ime modela
 Numéro Modelo / Modell neve / Nombre del modelo /
 Názov modelu / Ime modela / Denumire model /
 Nome do modelo

Sarina

Modellnummer / Number / Numéro du modèle
 Numero / modello /
 Číslo modelu / Modell száma / Eíslo modelu
 Številka modela / Număr model

3047AW Artisan / Weiss

Type / Tipo / Típus / Typ / Tip

20

D Bitte lesen Sie diese Montageanleitung gut durch, da wir für Fehler, die durch falsche Montage entstehen, keine Haftung übernehmen!

GB Please read these installation instructions through carefully as we cannot accept any liability for faults occurring as a result of incorrect installation!

CZ Přečtěte si prosím pozorně tento návod k montáži, aby jste předešli chybám vzniklých špatnou montáží, za které neručíme!

F Veuillez lire attentivement cette notice de montage, car nous déclinons toute responsabilité en cas d'erreurs découlant d'un montage erroné !

I Prego leggere attentamente le istruzioni per il montaggio, poiché decliniamo qualsiasi responsabilità per difetti derivanti da un montaggio errato

ES Por favor lea estas instrucciones de instalación con cuidado, ya que no podemos aceptar ninguna responsabilidad por fallos que ocurran como resultado de una instalación incorrecta!

NL Leest u alstublieft deze montagehandleiding goed door, voor fouten door verkeerde montage zijn wij niet verantwoordelijk.

PL Proszę uważnie zapoznać się z instrukcją montażu, ponieważ nie ponosimy odpowiedzialności za niewłaściwy montaż.

HR Molimo vas da pažljivo prčitajte uputstva za sastavljanje, jer ne snosimo odgovornost za pogreške nastale zbog ne odgovarajućeg sastavljanja.

HU Kérjük, olvassa el figyelmesen ezt az összeszerelési útmutatót, mert a helytelen összeszerelésből a dádó hibáért nem vállalunk felelősséget!

SK Prosíme, dobre prečítajte si tento návod na montáž, pretože nepreberáme žiadne ručenie za chyby, ktoré vzniknú na základe chýbnej montáže!

SLO Preberite ta navodila za montažo, ker mi ne prevzemamo odgovornosti za napake, ki nastanejo kot posledica napacne montaže!

RO Vă rugăm să citiți cu atenție aceste instrucțiuni de montaj deoarece nu preluăm garanția pentru defecte ce apar datorită unui montaj incorrect!

PT Leia estas instruções de instalação cuidadosamente, pois não podemos aceitar qualquer responsabilidade por falhas que ocorram como resultado de uma instalação incorreta!

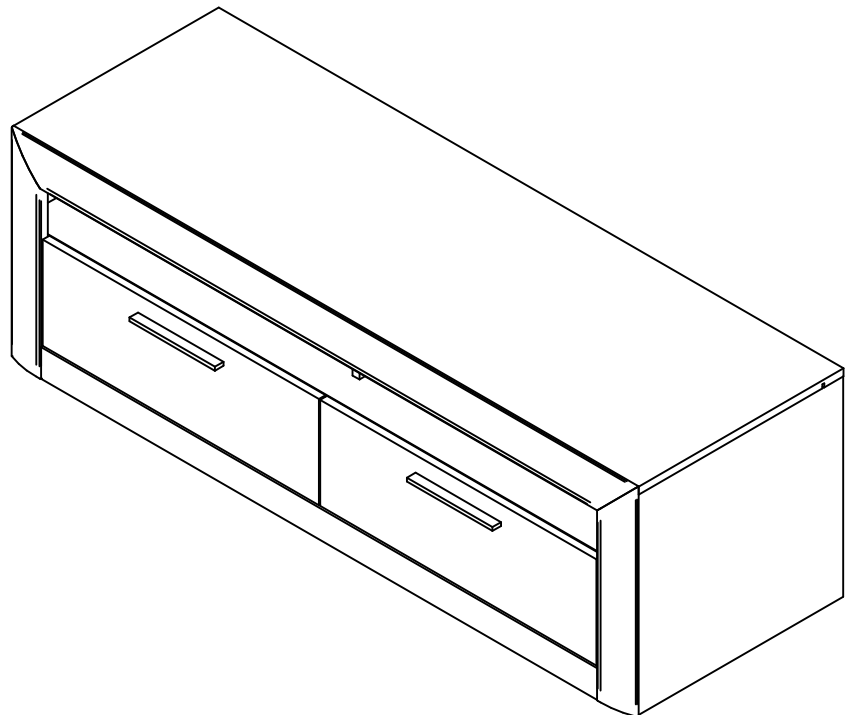

12.03.2020

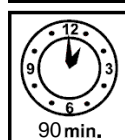
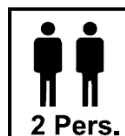
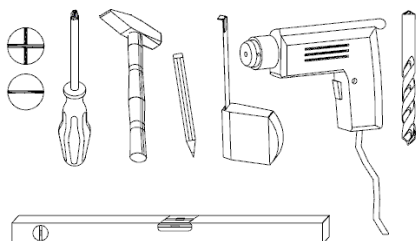

festziehen / tighten / apretar /
 serrer / stringere utånout / vasttrekken /
 zategnuti / strångere / zwiázac /
 szorosan meghúzni / pevne dotiahnut /
 trdno pritegniti / apertar /



eindrücken / press in / enfoncer /
 ribattere / zatlačit / presionar /
 Benyomni / stlačit / vtisniti / pressione
 introducere prin apasare /



ausmessen / measure / mesures /
 misurare / opmeten / izmeriti / miara /
 kimérni / izmeriti / masurare / medida
 zméřit / a medida



drücken / press / presser / stisknout /
 HaTNCHeTe / vtisniti / nasinac / drukken /
 pritisnuti / nacişnac / pritisniti / prensa /
 (Meg)nyomni / apasare /



einschlagen / hammer in / bevern / sla in
 frapper au marteler / infossare / Zabit' /
 zarazit / virar / zabiti /
 Introducere prin båtãie / tacha



Drehen - wenden / Proszde odwrócić /
 Keren - omdraaien / Girare - Ruotare /
 Okrenuti - ubnuti / Retourner - renverser /
 Turn over - turn around / Otocte - obrãte /
 Giro de vuelta / Obrnite list /
 Intoarceti / rotiti /

<p>Sehr geehrter Kunde,</p> <p>als Möbelproduzent möchten wir Sie darüber informieren, dass eine Befestigung nur so gut ist wie die Verbindung zwischen Befestigungsmaterial (Dübel) und Mauerwerk. Prüfen Sie bei Hängeelementen Ihr Mauerwerk und verwenden Sie nur dafür vorgesehene Dübel aus einem Fachmarkt. Letztendlich ist der Monteur für die Befestigung am Mauerwerk verantwortlich.</p> <p>Die Montage und das Verlegen der Elektroartikel sind nur von autorisiertem Fachpersonal durchzuführen. Beachten Sie die Beschreibungen und die Gewichtangaben in der Montageanleitung. Halten Sie bitte die angegebenen max. Gewichtangaben ein. Bei Überlastungen, die durch spielende Kinder, Menschen, Material oder sonstige Einwirkungen entstehen -übernehmen wir als Möbelproduzent keine Haftung!</p> <p>Die einwandfreie Funktion des Möbels ist nur bei lot- und waagerechter Aufstellung gewährleistet. Die Türen sind vorjustiert, müssen aber ggf. aufgrund örtlicher Bedingungen neu ausgerichtet / eingestellt werden!</p> <p>Alle elektrischen Installationen sind nach den gültigen Normen bzw. Vorschriften von VDE, CE, MM gefertigt. Die zu verwendende Leuchtmittelstärke ist auf der jeweiligen Lampenfassung angegeben.</p> <p>Bei Nichteinhaltung der max. Wattzahl besteht durch Überhitzung Brandgefahr. Das Zudecken der Leuchtmittel ist wegen Brandgefahr zu unterlassen!</p> <p>Alle Schrauben sowie tragende Verbindungsstelle sollten nach 5 bis 6 Wochen nachgezogen werden, um eine dauerhafte Standsicherheit zu gewährleisten!</p> <p>Keine scheuernden Putzmittel verwenden!</p> <p>Werden Betriebs-, Bedienungs- oder Montageanweisungen nicht befolgt, Änderungen an den Produkten vorgenommen, Teile ausgewechselt oder Verbrauchsmaterialien verwendet, die nicht den Originalteilen entsprechen, so entfällt jegliche Gewährleistung und Haftungsansprüche.</p>	<p>Dear Customer,</p> <p>As a furniture manufacturer we would like to point out that an attachment is only as good as the con-nection between the attachment material (dowel) and masonry. In the case of suspension elements you should check your masonry and only use the appropriate dowels from a specialist store. Ultimately it is the person carrying out the installation who is responsible for attachment to the masonry.</p> <p>The installation and laying of electrical lines and other items must only be performed by authorised specialists. Please note the descriptions and weight information in the installation instructions.</p> <p>Please observe the stated maximum weights; in the case of mechanical overloads caused by playing children, other individuals, materials etc. we do not accept any liability as the manufacturer of the furni-ture!</p> <p>The furniture is only guaranteed to work perfectly if it is set up to be plumb and horizontal. The doors have been pre-adjusted, but may need to be realigned/readjusted in accordance with local conditions!</p> <p>All electrical installations have been produced in accordance with the latest norms and regulations, such as those of the VDE (Association of German Electrical Engineers), CE and MM. The power of the bulbs to be used is marked on the respective light fitting.</p> <p>If the maximum number of watts stated on the fitting is not complied with, there is a danger of fire from overheating. Covering the lamps and bulbs is strictly prohibited due to the danger of fire!</p> <p>All screws and load-bearing connecting parts should be tightened after 5 to 6 weeks in order to ensure long-term stability!</p> <p>Do not use any abrasive cleaning materials!</p> <p>If the operating or installation instructions are not complied with, modifications are carried out to the products, parts replaced or consumable materials used which do not correspond to the original parts, all warranty or liability claims shall become null and void.</p>	<p>Vážení zákazniku,</p> <p>jako výrobce nábytku bychom Vás chtěli informovat o tom, že upevnění je jen tak dobré, jak dobré je spojení mezi upevňovacím materiálem (hmoždinkou) a zdívem. U závěsných prvků zkontrolujte příslušné zdivo a používejte jen vhodné hmoždinky, které nakupíte v odborných obchodech. Za upevnění ve zdivu je nakonec zodpovědný ten, kdo upevnění montuje.</p> <p>Montáž a instalaci elektrických částí směřjí provádět jen pověření odborní pracovníci. Dodržujte popisy a údaje o hmotnosti uvedené v návodu k montáži.</p> <p>Dodržujte uvedené údaje o maximální hmotnosti – při přetížení, které je způsobeno hrajícími si dětmi, lidmi, materiálem nebo jinými vlivy, nepřebíráme jako výrobce nábytku žádnou záruku!</p> <p>Bezvadná funkce nábytku je zaručena jen při postavení nábytku ve správně svíslé a vodorovné poloze. Dvířka jsou předem nastavená, případně je ale nutné je znovu seřídit / nastavit podle místních podmínek!</p> <p>Všechny elektrické instalace jsou provedeny podle platných norem příp. předpisů VDE (svaz německých elektrotechniků), CE, MM. Intenzita žárovky/zdroje světla, která se má použít, je uvedena na příslušné objímce žárovky/zdroje světla.</p> <p>Při nedodržení maximálního výkonu ve Watech hrozí nebezpečí vznícení kvůli přehřátí. Zakrytí žárovky/zdroje světla je kvůli nebezpečí požáru zakázáno!</p> <p>Všechny šrouby a nosné spojovací prvky se mají po 5 až 6 týdnech dotáhnout, čímž se zajistí trvalá stabilita!</p> <p>Nepoužívejte žádné odírající čisticí prostředky!</p> <p>Pokud se nedodržují pokyny k provozu, návodu nebo montáži, provádí se změny výrobků, vyměňují se díly na neoriginální nebo se používají spotřební materiál, který neodpovídá originálnímu, odpadá každá záruka nebo nároky na ručení.</p>
<p>Tisztelt Ügyfelünk!</p> <p>Mint bútorgyártó arról szeretnénk tájékoztatni Önt, hogy a rögzített szerkezetek minősége a rögzítő anyag (típl) és a fal közti összeköttetés minőségétől függ. Falra szerelt egységek esetén ellenőrizze a fal adottságait és csakis szakköreskedelemből származó, a rögzítéshez megfelelő típliket használjon. Végső soron a bútort felszerelő személy felelős a falra történő rögzítésért.</p> <p>A villamosági cikkek szerelését és elhelyezését csakis erre jogosult szakember végezheti. Kérjük, vegye figyelembe az összerelési útmutatóban szereplő leírásokat és a súlyadatokat.</p> <p>Tartsa be a megadott maximális súlyhatárokat. A bútor játszó gyermekek, személyek, anyagok vagy egyéb behatások okozta túlterhelésért a bútorgyártót nem terheli felelősség.</p> <p>A bútor kifogástalan működése csakis pontosan függőleges helyzetben garantált. Az ajtók előre be vannak állítva, a helyi adottságok függvényében azonban szükség esetén újra be kell állítani/igazítani őket.</p> <p>A villamos berendezések a német VDE, CE és MM érvényes szabványainak és előírásainak megfelelően készültek. A világítótestek megfelelő erőssége az adott lámpa foglalatán található meg.</p> <p>A max. watt-szám be nem tartása esetén túlforródás következtében fellépő tűzveszély áll fenn. A világítótesteket tűzveszély miatt nem szabad letakarni!</p> <p>Minden csavart és tartó összekötő részt 5-6 hét elteltével újra meg kell húzni a bútor álló helyzetben való tartás biztonsága érdekében.</p> <p>Nem használjon habzó tisztítószereket!</p> <p>Az üzemeltetési, kezelési ill. szerelési útmutató utasításainak be nem tartása, a termékek végzett változtatások, részek kicserélése, vagy az eredeti részeknek meg nem felelő anyagokat felhasználása esetén mindennemű szavatosság és felelősség kizárt.</p>	<p>Vážení zákaznik,</p> <p>ako výrobca nábytku by sme Vás chceli informovať o tom, že nové upevnenie je len také dobré, aké dobré je spojenie medzi spojovacím materiálom (hmoždinky) a murivom. Pri visiacich elementoch skontrolujte Vaše murivo a použite na príslušné murivo iba určenú hmoždinku zo stavebnín. V konečnom dôsledku je za upevnenie na murive zodpovedný montér.</p> <p>Montáž a pokládku elektrických materiálov a spotrebičov smie vykonávať iba autorizovaný odborný personál. Prosíme, dodržte popisy a údaje o hmotnosti v návode na montáž.</p> <p>Dodržiavajte uvádzané údaje o maximálnej hmotnosti – pri preťažení, ktoré môžu spôsobiť hrajuce sa deti, ľudia, materiál, alebo iné vplyvy - my, ako výrobca nábytku nepreberáme žiadne ručenie!</p> <p>Bezchybná funkcia nábytku je zaručená iba pri kolmom a vodorovnom postavení. Dvere sú vopred nastavené, v prípade potreby na základe miestnych podmienok je však nutné ich znovu vyvážiti/nastaviť!</p> <p>Všetky elektrické inštalácie sú zhotovené podľa platných noriem, resp. predpisov VDE, CE, MM. Síla osvetľovacích telies, ktoré sa majú použiť, je uvedená objímkach príslušných žiaroviek.</p> <p>Pri nedodržaní maximálnych Wattov vzniká na základe prehriatia riziko požiaru. Neprikrývajte osvetľovacie telesá kvôli riziku požiaru!</p> <p>Všetky skrutky, ako aj nosné spojovacie diely by sa mali po 5 až 6 týždňoch dotiahnuť, aby bola zaručená trvalá stabilita!</p> <p>Nepoužívajte žiadne drsné čistiace prostriedky!</p> <p>Ak nebudú dodržané prevádzkové návody, návody na obsluhu alebo montáž, ak sa budú na produktoch vykonávať zmeny, vymieňať diely alebo ak sa bude používať spotrebný materiál, ktorý nezodpovedá originálnym dielom, odpadá akákoľvek záruka alebo akékoľvek nároky na ručenie.</p>	<p>Spoštovani,</p> <p>kot proizvajalec pohištva vas želimo informirati, da je pritrđitev samo tako močna, kot je močna povezava med pritrđilnim materialom (moznikom) in zidom. Pri elementih, ki so obešeni, preverite zid in uporabite samo za zidove primerne moznike, ki ste jih nabavili v strokovni trgovini. Nenazadnje odgovarja monter za pritrđitev.</p> <p>Električne artikle naj vam položi in montira strokovnjak. Pri tem upoštevajte opise ter podatke o teži v navodilih za montažo.</p> <p>Upoštevajte podano maksimalno težo - pri previsokih obremenitvah, ki nastanejo zaradi igranja otrok, bremen ljudi ali drugega materiala ali zaradi drugih obremenitev - kot proizvajalec pohištva ne prevzemamo nikarkršne odgovornosti!</p> <p>Pravilno delovanje funkcij pohištva je zagotovljeno samo pri pravilni vodoravni in pravokotni postavitvi. Vrata so predhodno justirana, vendar jih je treba zaradi lokalnih pogojev na novo nastaviti!</p> <p>Vse električne instalacije so izdelane v skladu z veljavnimi standardi od. predpisi VDE, CE in MM. Jakost uporabljenih žarnic je vedno navedena na vsakem posameznem okviru za svetilo.</p> <p>Pri neupoštevanju maks. števila watov obstaja zaradi pregretja nevarnost požara. Svetil zaradi nevarnosti požara ni dopustno prekrivati!</p> <p>Vse vijake in nosilne povezovalne dele po 5 do 6 tednih naknadno privijajte, da boste zagotovili stalno trdnost povezav!</p> <p>Ne uporabljate čistil za drgnjenje!</p> <p>V primeru neupoštevanja navodil za delovanje, uporabo in montažo, in v primeru izvajanja sprememb na produktih ter menjave delov ali porabnega materiala, ki ne ustrezajo originalnim delom, izgubi kupec vse pravice do uveljavljanja garancije.</p>
<p>Gentile cliente,</p> <p>in qualità di produttori di mobili desideriamo informarla del fatto che un fissaggio può essere solo veramente buono se anche il collegamento tra il materiale di fissaggio (bullone) e le mura è altrettanto buono. Nel caso degli elementi che pendono controllate le vostre mura ed utilizzate solamente bulloni previsti a tale scopo che troverete in un mercato specializzato. Infine è il montatore colui che è responsabile per il fissaggio sulla parete.</p> <p>Il montaggio e la messa in funzione degli apparecchi elettronici devono essere effettuati esclusivamente da personale specializzato. Si prega di rispettare le descrizioni e le indicazioni relative al peso presenti nelle istruzioni per il montaggio.</p> <p>Si prega di rispettare le indicazioni relative al peso massimo - nel caso di un sovra-caricamento che può essere causato da bambini che giocano, da persone, da materiale oppure altri influssi si declina qualsiasi responsabilità!</p> <p>Il funzionamento corretto del mobile è garantito solamente in caso di un montaggio corretto in posizione orizzontale e come riportato sull'imballaggio. Le porte sono già state anticipatamente pre-impostate, essere dovranno però, qualora necessario, essere adattate / regolate conformemente alle nuove condizioni ambientali!</p> <p>Tutte le installazioni elettriche sono preparate secondo le norme e le regole vigenti VDE, CE, MM. La potenza dei mezzi d'illuminazione da utilizzarsi è riportata sul rispettivo zoccolo della lampada.</p> <p>In caso di non-rispetto del numero massimo di Watt può verificarsi un surriscaldamento con il pericolo d'incendio. È vietato coprire i mezzi d'illuminazione perché sussiste il pericolo d'incendio!</p> <p>Tutte le viti e gli elementi portanti di collegamento dovrebbero essere ri-aggiustati dopo 5 o 6 settimane al fine di garantire un funzionamento sicuro continuativo!</p> <p>Non utilizzare mezzi di pulizia che creino polvere di pulizia!</p> <p>In caso di mancato rispetto delle indicazioni per l'esercizio, il comando o il montaggio, nel caso in cui venissero effettuate delle modifiche ai prodotti, in cui venissero sostituiti degli elementi oppure in cui venissero utilizzati dei materiali ausiliari che non corrispondono ai pezzi originali, allora non sarà più esigibile nessuna garanzia o nessuna richiesta di garanzia.</p>	<p>Cher client,</p> <p>En tant que fabricant de meubles, nous souhaitons attirer votre attention sur le fait que la meilleure des fixations n'est rien sans la qualité du raccord entre le matériel de fixation (cheville) et la maçonnerie. Par conséquent, pensez à vérifier la maçonnerie avant d'accherer les éléments hauts et utilisez uniquement les chevilles prévues à cette fin, achetées dans une grande surface spécialisée. En fin de compte, c'est l'installateur qui sera responsable de la fixation à la maçonnerie.</p> <p>Le montage et la pose des articles d'électroménager sont strictement l'affaire d'un personnel qualifié, dûment habilité. Veuillez observer les descriptions et les poids indiqués dans la notice de montage.</p> <p>Veuillez respecter les poids maxi spécifiques ; en tant que fabricant de meubles, nous déclinons toute responsabilité en cas de surcharges causées par des enfants qui jouent, d'autres personnes, du matériel divers ou provoqués par d'autres influences !</p> <p>Pour assurer le fonctionnement irréprochable du meuble, il faut veiller à l'installer parfaitement d'aplomb et à l'horizontale. Les portes sont préajustées, mais il sera peut-être nécessaire de les réaligner/régler à nouveau sur place !</p> <p>Toutes les installations électriques sont fabriquées selon les normes et prescriptions VDE, CE, MM en vigueur. La puissance à utiliser est précisée sur la douille de chaque lampe.</p> <p>Si le wattage max. n'est pas respecté, il existe un risque d'incendie dû à la surchauffe. Il est interdit de recouvrir la lampe, en raison du risque d'incendie !</p> <p>Il faut resserrer toutes les vis et les éléments de raccord porteurs après 5 à 6 semaines, pour assurer une stabilité durable !</p> <p>N'employez aucun cas des nettoyeurs abrasifs !</p> <p>Si les instructions de service, de commande ou de montage ne sont pas respectées, si des modifications sont apportées aux produits ou bien encore si des pièces sont remplacées ou si des consommables qui ne correspondent pas aux pièces d'origine sont utilisés, nous n'assurons alors aucune garantie et nous déclinons toute responsabilité dans ces cas.</p>	<p>Geachte klant,</p> <p>Als meubelproducent willen wij u erover informeren dat een bevestiging slechts zo goed is als de verbinding tussen het bevestigingsmateriaal (plug) en de muur. Controleer daarom bij aan de muur hangende elementen uw muurconstructie en gebruik alleen hiervoor geschikte pluggen uit een specialzaak. Tenslotte is de monteur verantwoordelijk voor de bevestiging aan de muur.</p> <p>De montage en het leggen van kabels van elektrische artikelen mag uitsluitend door hiervoor bevoegd vakpersoneel worden uitgevoerd. Houd ook rekening met de beschrijvingen en de vermelde gewichten in de montagehandleiding.</p> <p>Neem de aangegeven maximumgewichten in acht. Bij overbelasting die door spelende kinderen, personen, materiaal of overige invloeden ontstaat, zijn wij als meubelproducent niet aansprakelijk!</p> <p>Het onberispelijk functioneren van het meubel is alleen gegarandeerd, wanneer dit horizontaal en verticaal waterpas wordt opgesteld. De deuren zijn vooraf ingesteld, moeten echter eventueel door de omstandigheden ter plaatse opnieuw worden afgesteld / ingesteld!</p> <p>Alle elektrische aansluitingen voldoen aan de geldende normen resp. voorschriften van VDE, CE, MM. Het te gebruiken lampwattage is aangegeven op de betreffende lampfitting.</p> <p>Wanneer het maximaal geoorloofde wattage niet wordt aangehouden, bestaat brandgevaar door oververhitting. Het afdekken van de lamp is in verband met brandgevaar verboden!</p> <p>Alle schroeven en dragende verbindingselementen moeten na 5 à 6 weken worden aangedraaid om een duurzame stabiliteit te waarborgen!</p> <p>Gebruik geen schurende schoonmaakmiddelen!</p> <p>Wanneer gebruiksvorschriften, bedienings- of montage-instructies niet worden opgevolgd, veranderingen aan de producten worden uitgevoerd, onderdelen worden vervangen of verbruiksmaterialen gebruikt, die niet overeenkomen met de originele onderdelen, vervalt iedere garantie of aansprakelijkheid.</p>

Szanowni Klienci!

Jako producent mebli pragniemy Państwu przypomnieć, że umocowanie mebli jest tak dobre, jak dobre jest połączenie pomiędzy materiałem mocującym (kolkiem rozporowym) a ścianą. Proszę zatem w przypadku elementów wiszących sprawdzić wytrzymałość muru i użyć do ich zamocowania wyłącznie przeznaczonych do tego kolków ze sklepu specjalistycznego. Ostateczną odpowiedzialność za przymocowanie do ściany ponosi monter mebli.

Montaż artykułów elektrycznych i ich ułożenie należy powierzyć wyłącznie autoryzowanemu personelowi. Proszę zastosować się do opisów oraz ciężarów podanych w instrukcji montażu.

Proszę przestrzegać podanych ciężarów maksymalnych. W przypadku nadmiernego obciążenia, powstałego w wyniku bawiących się dzieci, osób, materiału lub z innych powodów – jako producent mebli nie ponosimy odpowiedzialności!

Nienaganne funkcjonowanie mebla jest zagwarantowane wyłącznie w przypadku jego prawidłowego pionowego i poziomego ustawienia. Drzwi zostały odpowiednio ustawione, ale ze względu na warunki lokalne należy je ewentualnie ustawić na nowo/wyregulować!

Wszystkie instalacje elektryczne wykonano zgodnie z obowiązującymi normami lub przepisami VDE, CE, MM. Na każdej oprawce lampowej podana jest moc żarówek, których należy używać.

W przypadku nieprzestrzegania maksymalnej ilości watów istnieje niebezpieczeństwo pożaru w wyniku przegrzania. Żarówek nie wolno przykrywać ze względu na niebezpieczeństwo pożaru!

Dla zapewnienia trwałej stateczności po 5-6 tygodniach należy dokręcić wszystkie śruby i nośne elementy łączące! Nie używać żadnych środków czyszczących wymagających szorowania!

W przypadku nieprzestrzegania instrukcji użytkowania, obsługi i montażu, dokonywania zmian w produktach, wymiany części lub używania materiałów zużywających się, które nie odpowiadają częściom oryginalnym, wyklucza się jakkolwiek gwarancję lub roszczenia z tytułu odpowiedzialności cywilnej.

Estimado Cliente

Como fabricante de muebles queremos señalar que un accesorio es tan bueno como la conexión entre el material de fijación (clavija) y la mampostería. En el caso de los elementos de la suspensión usted debe comprobar su albañilería y utilizar solamente las espigas apropiadas de una tienda especializada. En última instancia es la persona que lleva a cabo la instalación que es responsable de la conexión a la mampostería.

La instalación y colocación de líneas eléctricas y otros elementos sólo deben ser realizados por especialistas autorizados. Tenga en cuenta las descripciones y la información de peso en las instrucciones de instalación.

Por favor, observe los pesos máximos indicados; en el caso de sobrecargas mecánicas causadas por jugar niños, otras personas, materiales, no aceptamos ninguna responsabilidad como el fabricante de los muebles!

El mobiliario sólo está garantizado para funcionar perfectamente si está configurado justamente para ser plumb y horizontal. Las puertas se han preajustado, pero puede que tenga que ser realineado / reajustado de acuerdo con las condiciones locales!

Todas las instalaciones eléctricas han sido fabricadas de acuerdo con las últimas normas y normas, como las de la VDE (Asociación de Ingenieros Eléctricos Alemanes) CE y MM. La potencia de las lámparas que se van a utilizar se marca en la luminaria correspondiente.

Si no se cumple el número máximo de vatios indicado en el accesorio, existe peligro de incendio por sobrecalentamiento. Cubrir las lámparas y bombillas está estrictamente prohibido debido al peligro de incendio.

Todos los tornillos y piezas de conexión de carga deben apretarse después de 5 a 6 semanas para garantizar la estabilidad a largo plazo.

¡No utilice materiales de limpieza abrasivos!

En caso de incumplimiento de las instrucciones de funcionamiento o de instalación, se realizarán modificaciones en los productos, piezas reemplazadas o consumibles que no correspondan a las piezas originales, quedarán anuladas todas las reclamaciones de garantía o responsabilidad.

Cijenjeni kupče,

kao proizvođač namještaja želimo Vas informirati o tome da učvršćenje drži ukoliko je dobar spoj između materijala za pričvršćenje (moždanik) i zida. Kod visećih elemenata ispitajte zide i koristite samo moždanike predviđene za to iz specijalizirane stručne trgovine. Najzad, monter je odgovoran za učvršćenje na zidu.

Montažu i položnje elektro-artikala može izvršavati samo autorizirano stručno osoblje. Pazite na opise i podatke o težini u uputstvu za montažu.

Pridrđavajte se navedenih podataka o maksimalnoj težini – u slučaju preopterećenja izazvanih zbog djece koja se igraju, ljudi, materijala ili drugih utjecaja – kao proizvođač namještaja ne preuzimamo garanciju!

Besprijeckoma funkcija namještaja je zajamčena samo kod vertikalne i vodoravne montaže. Vrata su prednamještena, ali u danom slučaju se moraju nanovo centrirati / podesiti, na osnovi lokalnih uvjeta!

Sve električne instalacije su izvedene prema vrijedećim VDE-, CE-, MM-normama odnosno

-propisima. Jačina rasvjetnog sredstva koju treba koristiti, navedena je na dotičnom grlu žarulje.

U slučaju nepridrđavanja maksimalne vataže, postoji opasnost od požara zbog pregrijavanja. Ne smije se pokriti rasvjetno sredstvo zbog opasnosti od požara!

Sve vijke kao i noseće spojne dijelove treba naknadno pritegnuti poslije 5 do 6 tjedana da bi tako bila zajamčena trajna stabilnost! Nemojte koristiti ribajuća sredstva za čišćenje!

Ukoliko se na pridrđavate pogonskoj uputi, uputi za rad ili za montažu, ako vršite promjene na proizvodima, izmijenite dijelove ili koristite potrošne materijale koji ne odgovaraju originalnim dijelovima, otpada svaka garancija i svaki zahtjev za jamčenjem.

Stimate client!

În calitate de producător de mobilă am dori să vă informăm că o fixare poate fi bună doar dacă legătura dintre materialul de fixare (dibluri) și zid este bună. În cazul elementelor suspendate verificați zidul și folosiți doar diblurile prevăzute și achiziționate dintr-un magazin de specialitate. În definiiv montatorul este răspunzător de fixarea pe zid.

Montarea și pozarea articolelor electrice se va efectua doar de către personal calificat și autorizat. Respectați descrierea și specificațiile de greutate din instrucțiunile de montaj.

Vă rugăm să respectați specificațiile date privind greutatea max. - În caz de supraîncărcare ce poate să apară datorită copiilor care se joacă, datorită persoanelor, materialului sau prin alți factori - nu preluăm niciun fel de răspundere ca producător de mobilă!

O funcționalitate perfectă a mobilei este asigurată doar în cazul în care la așezare aceasta se reglează pe orizontală și pe verticală. Ușile sunt deja reglate în prealabil, dar dacă va fi cazul, din motive existente la fața locului, acestea trebuie din nou ajustate / reglate!

Toate instalațiile electrice sunt fabricate conform normelor în vigoare respectiv prevederilor VDE, CE, MM. Puterea necesară a becului este trecută pe dulia respectivă a lămpii.

Dacă nu se respectă puterea max. în Watt există pericol de incendiu datorită supraîncălzirii. Datorită pericolului de incendiu este interzisă acoperirea becurilor!

Toate șuruburile și piesele portante de îmbinare trebuie strânse ulterior după 5 până la 6 săptămâni pentru a se asigura o siguranță definitivă a fixării! Nu folosiți agenți de curățire abrazivi!

În cazul în care nu se respectă instrucțiunile de utilizare, de deservire sau de montaj, dacă se efectuează modificări ale produselor, dacă se schimbă piese sau se folosesc materiale consumabile care nu corespund pieselor originale, atunci se pierde orice garanție sau pretenție de responsabilitate.

Estimado Cliente

Como fabricante de móveis, gostaríamos de salientar que um anexo é tão bom quanto a conexão entre o material de anexo (cavilha) e alvenaria. No caso de elementos de suspensão, você deve verificar sua alvenaria e usar apenas as cavilhas apropriadas de uma loja especializada. Em última análise, é a pessoa que realiza a instalação responsável pelo apego à alvenaria.

A instalação e colocação de linhas elétricas e outros itens só devem ser realizados por especialistas autorizados. Observe as descrições e informações de peso nas instruções de instalação.

Observe os pesos máximos indicados; no caso de sobrecargas mecânicas causadas pela reprodução de crianças, outros indivíduos, materiais. Nós não aceitamos qualquer responsabilidade como fabricante dos móveis!

O mobiliário só é garantido para funcionar perfeitamente se estiver configurado para ser prumo e horizontal. As portas foram pré-ajustadas, mas podem precisar ser realinhadas / reajustadas de acordo com as condições locais.

Todas as instalações elétricas foram produzidas de acordo com as mais recentes normas e regulamentos, como os da VDE (Associação de Engenheiros Eléctricos Alemães) CE e MM. O poder das lâmpadas a serem usadas está marcado no respectivo encaixe de luz.

Se o número máximo de watts indicado no encaixe não for cumprido, há um risco de incêndio contra o superaquecimento. Cobrir as lâmpadas e as lâmpadas é estrictamente proibido devido ao perigo de incêndio!

Todos os parafusos e as peças de ligação do suporte de carga devem ser apertados após 5 a 6 semanas, a fim de garantir a estabilidade a longo prazo!

Não use materiais de limpeza abrasivos!

Se as instruções de operação ou instalação não forem cumpridas, as modificações são realizadas nos produtos, peças substituídas ou materiais consumíveis utilizados que não correspondem às peças originais, todas as reivindicações de garantia ou responsabilidade serão anuladas e nulas

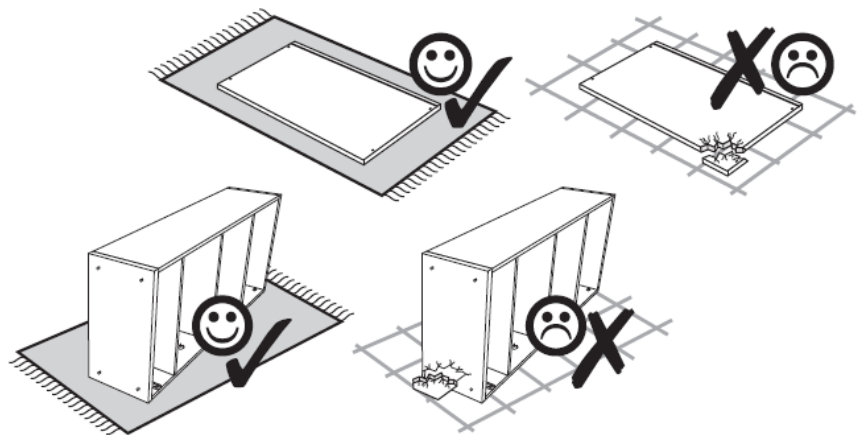
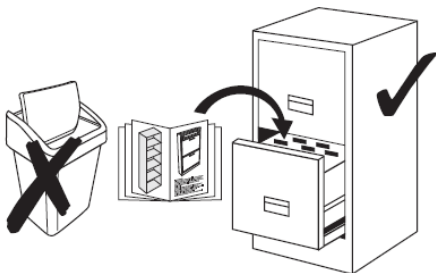
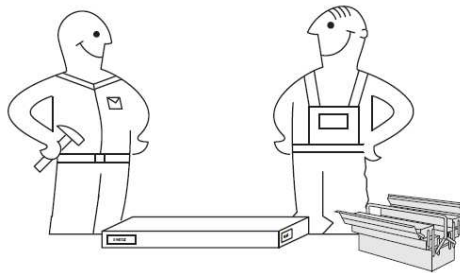

Pflege und Reinigung hochglänzender Oberflächen

Für die Reinigung sollten Sie ausschließlich **leicht mit Wasser angefeuchtete Microfasertücher** benutzen. **Es dürfen keine anderen Tücher verwendet werden!**



Alle eingesetzten Tücher müssen sauber sein und dürfen keine Verschmutzungen wie Sand- oder Staubkörner enthalten, da es sonst zum Verkratzen der Oberfläche kommen kann.

Sollten die eingesetzten Tücher einen genähten oder ähnlichen Rand besitzen, ist es wichtig, dass Sie mit diesem Rand keinen Druck auf die Oberfläche ausüben!

Verzichten Sie auf den Einsatz von Putzmitteln!



Es können mikroskopisch kleine Gebrauchsspuren entstehen, die je nach Farbe und Lichteinfall mehr oder weniger auffallen.

Gebrauchsspuren stellen keine Minderung des Gebrauchswertes dar, sondern sind wie bei allen hochglänzenden Oberflächen an Autos, Gläser etc. langfristig nicht zu vermeiden.

Hochglänzende Oberflächen wirken edel und überzeugen langfristig über das gesamte Design.

Wenn Sie die wenigen Pflegehinweise beachten, werden Sie sehr lange Freude an Ihrem Wohnmöbel haben.

Reiniging en onderhoud van hoogglanzende oppervlakken

Gebruik voor de reiniging uitsluitend **licht met water bevochtigde microvezeldoekjes**. **Andere doeken mogen niet worden gebruikt!**



Alle gebruikte doeken moeten schoon zijn. Zelfs lichte verontreinigingen als zand- of stofdeeltjes kunnen krassen op het oppervlak veroorzaken.

Wanneer u doeken met een genaaiete of soortgelijke rand gebruikt, is het belangrijk dat u met deze rand geen druk uitoefent op het oppervlak!

Gebruik geen schoonmaakmiddelen!



Er kunnen microscopisch kleine gebruikssporen ontstaan, die afhankelijk van de kleur en lichtinval meer of minder opvallen.

Gebuuksporen hebben geen invloed op de gebruikswaarde, maar zijn net als bij alle hoogglanzende oppervlakken van auto's, ruiten e.d. op lange termijn niet te vermijden.

Hoogglanzende oppervlakken hebben een hoogwaardige uitstraling en overtuigen op lange termijn met het totaalbeeld.

Als u deze weinige veiligheidsvoorschriften opvolgt, zult u heel lang plezier beleven aan uw meubelstuk.

Entretien et nettoyage des surfaces ultra-brillantes

Pour effectuer le nettoyage, utilisez exclusivement des chiffons en microfibre légèrement humidifiés d'eau. **L'utilisation de tous autres chiffons est absolument proscrite !**



Tous les chiffons utilisés doivent être propres et ne contenir aucune saleté telle que des grains de sable ou de poussière, car cela risquerait de provoquer des égratignures à la surface.

Si les chiffons utilisés présentent des bordures cousues ou similaires, il faut veiller à ne pas exercer de pression sur la surface avec les bordures en question !

Il convient de renoncer à utiliser des produits d'entretien !



Sinon, il pourrait se former des traces d'utilisation microscopiques, plus ou moins visibles selon la couleur et les conditions de luminosité.

Les traces d'utilisation ne représentent pas une diminution de la valeur d'usage et ne peuvent pas être évitées à long terme, comme c'est d'ailleurs le cas pour toutes les surfaces ultra-brillantes des voitures, des verres, etc.

D'aspect noble, les surfaces ultra-brillantes savent convaincre au long terme par l'ensemble du design.

Si vous tenez compte de ces quelques conseils d'entretien, vous pourrez réellement profiter longtemps de votre mobilier.

Care and cleaning of high-gloss surfaces

Always wipe surfaces with a **microfibre cloth slightly moistened with water**. **Do not use any other type of cloth!**



Make sure that the cloth used is clean and free from contamination such as dust and sand to avoid scratching of the surfaces.

If the cloth used to wipe the surfaces has a sewn edge or similar border, it is important not to press hard against the surface with such edge or border.

Do not use cleaning agents!



Cleaning agents may leave microscopic traces on the surface which are more or less visible depending on colour and light conditions.

Signs of use do not detract from value but cannot be avoided in the long run, same as is the case with cars, glasses, etc.

High-gloss surfaces have a sophisticated effect and make for compelling and lasting design.

If you follow those few care instructions, you will enjoy your furniture for years to come.

Cura e Pulizia di superfici ultralucanti

Per la pulizia si consiglia di utilizzare esclusivamente **dei panni in microfibra inumiditi con acqua**. **Non utilizzare nessun altro tipo di panno!**



Tutti i panni impiegati devono essere puliti e non devono contenere nessun tipo di sporco, come granuli di sabbia o polvere, poiché ciò potrebbe provocare un'usura delle superfici.

Nel caso in cui i panni impiegati dovessero avere un bordo con cucitura o simili sarà importante non fare alcuna pressione sulle superfici con tale bordo!

Rinunciate all'impiego di detergenti!



Possono formarsi dei segni d'usura così piccoli da poter essere visti solamente al microscopio. Tali segni d'usura possono saltare più o meno all'occhio a seconda del colore e dell'irraggiamento solare.

I segni d'usura non rappresentano nessun vizio che riduca il valore d'utilizzo. Essi sono bensì, a lungo termine, inevitabili sulle superfici lucide di auto, vetri ecc.

Le superfici ultralucanti hanno un effetto nobile e a lungo termine convincono molto assieme all'intero design.

In caso di rispetto di queste poche indicazioni d'impiego potrete godere a lungo dei vostri mobili.

Pielęgnacja i czyszczenie powierzchni o wysokim połysku

Do czyszczenia należy używać wyłącznie **lekko zwilżonych wodą ściereczek z mikrowłókna**. **Nie wolno używać żadnych innych ściereczek!**



Wszystkie stosowane ściereczki muszą być czyste; na ich powierzchni nie mogą znajdować się żadne zabrudzenia w postaci ziarenek piasku lub cząstek pyłu, ponieważ w przeciwnym wypadku może dojść do porysowania powierzchni.

Jeżeli używane ściereczki miałyby obszuty lub podobnie wykończony brzeg, ważne jest, by nie przyciskać ich takim brzegiem do powierzchni!

Proszę zrezygnować z używania środków czyszczących!



Na powierzchniach o wysokim połysku mogą w wyniku używania powstawać ślady mikroskopijnej wielkości, zauważalne w mniejszym lub większym stopniu w zależności od koloru i padania światła.

Ślady te nie obniżają wartości użytkowej, lecz są w przypadku wszystkich powierzchni o wysokim połysku, obecnych w karoserii samochodowej, wyrobach szklanych itd., na dłuższą metę nie do uniknięcia.

Powierzchnie o wysokim połysku mają szlachetny wygląd i przekonują długookresowo swoją całościową prezentacją.

Jeżeli będą Państwo przestrzegać nielicznych wskazówek dotyczących pielęgnacji, zakupiony mebel będzie bardzo długo sprawiał Państwu radość.

Ošetřování a čištění povrchů s vysokým leskem

K čištění používejte pouze **hadříky z mikrovłákna zlehka navlhčené ve vodě**. **Není dovoleno používat žádné jiné textilie!**



Všechny používané hadříky musí být čisté, bez prachu a písku, protože jinak se povrch poškodí.

Mají-li hadříky, které používáte, zapořité okrajové lem nebo jiný podobný okraj, je důležité jím na čištěnou plochu netlačit!

Nepoužívejte čisticí prostředky!



Mohou zanechat mikroskopické stopy opotřebení, které budou v závislosti na barvě a úhlu dopadu světla více či méně viditelné.

Tyto stopy nesnižují užžitnou hodnotu produktu, ale stejně jako u všech vysoce lesklých povrchů na autech, skle apod. je nelze zcela vyloučit.

Povrchy s vysokým leskem působí ušlechtilé a trvale podporují celkový design.

Budete-li se při ošetřování řídit těmito několika málo zásadami, budete si dlouho vychutnávat radost ze svého nábytku.

Njega i čišćenje površina visokog sjaja

Za čišćenje treba koristiti isključivo **malo vodom ovlažene krpe za čišćenje iz mikro vlakna**. **Druge krpe se ne smiju upotrijebiti!**



Sve upotrijebljene krpe moraju biti čiste i ne smiju sadržavati onečišćenja kao što su zrna pijeska ili prašine, jer bi inače došlo do oštećenja na površini.

Ako krpe koje rabite, imaju rub od šivanja ili slično, važno je da tim rubom ne izvršavate pritisak na površinu!

Nemojte koristiti sredstva za čišćenje!



Mogu nastati mikroskopski mali tragovi uporabe, koji mogu manje ili više padati u oči, ovisno o boji i o upadu svjetla.

Tragovi uporabe ne predstavljaju smanjenje uporabne vrijednosti, nego se ne mogu dugoročno sprječiti kao što je to slučaj kod svih površina visokog sjaja na automobilima, čašama itd.

Površine visokog sjaja djeluju otmjeno i dugoročno uvjeravaju o cjelokupnom dizajnu.

Ukoliko obratite pozornost na ono malo uputa za njegu, vrlo dugo ćete se veseliti Vašem namještaju za stanovanje.

Cuidado y limpieza de superficies de alto brillo

Limpie siempre las superficies con un paño de microfibras ligeramente humedecido con agua. **¡No utilice ningún otro tipo de tela!**



Asegúrese de que el paño utilizado esté limpio y libre de contaminación, como polvo y arena, para evitar rasgar las superficies.

Si el paño usado para limpiar las superficies tiene un borde cosido o un borde similar, es importante no presionar fuertemente contra las superficies con tal borde o borde.

¡No utilice productos de limpieza!



Los agentes de limpieza pueden dejar operaciones microscópicas en la superficie que son más o menos visibles dependiendo del color y las condiciones de luz.

Los signos de uso no disminuyen el valor, pero no pueden evitarse a largo plazo, como ocurre con los coches, los cristales, etc.

La superficie de alto brillo tiene un efecto sofisticado y hace que el diseño sea convincente y duradero.

Si usted sigue las instrucciones de cuidado pocos, podrá disfrutar de sus muebles para los próximos años.

Tükörfényes felületek ápolása és tisztítása

Tisztításhoz kizárólag **enyhén benedvesített mikroszálás törölkendőt** használjon. **Másfajta törölkendőt nem szabad használni!**



A törölkendőnek mindig tisztának kell lennie, és nem szabad, hogy homok- vagy porszemek legyenek rajta, mert ezek karcoslatokat hagyhatnak hátra a tisztítandó felületen.

Ha a tisztítókendő széle levarrott vagy hasonló szerkezetű, ügyeljen arra, hogy ne gyakoroljon a kendő szélével nyomást a tisztítandó felületre!

Tisztítószeret ne használjon!



Előfordulhat, hogy mikroszkopikusan kicsi használati nyomok keletkeznek, melyek a felület színének illetve a ráeső fény beesési szögének függvényében különböző mértékben tűnnek fel.

A használati nyomok nem csökkentik a tárgy értékét és hosszú távon nem kerülhetők el, ahogy egyéb tükörfényes felületek, pl. autók, üvegpoharak, stb. esetében sem.

A tükörfényes felületek nemes benyomást keltenek és kiváló formatervezésről tesznek tanúbizonyosságot hosszabb idő elteltével is.

Ha betartja az ápolási utasításokat, bútora sokáig örömet fog okozni Önnek.

Întreținerea și curățarea suprafețelor finisate cu luciu oglindă

Pentru curățare este recomandat să utilizați exclusiv **lavete de microfibră ușor umezite cu apă**. **Nu este permis a se folosi altfel de lavete!**



Toate lavetele trebuie să fie curate și nu au voie să conțină impurități precum granule de nisip sau de praf, deoarece acestea ar putea produce zgărieturi pe suprafața ce se șterge.

Dacă lavetele folosite conțin o margine cusută sau ceva asemănător, este important să nu apăsați cu această margine pe suprafața ce se șterge!

Nu utilizați substanțe de curățat!



Se pot produce urme microscopice de uzură, mai mult sau mai puțin vizibile, depinzând de culoarea suprafeței și de cum cade lumina pe suprafața.

Urmele de uzură nu diminuează valoarea de utilizare, întrucât pe termen lung sunt inevitabile, la fel ca pe toate suprafețele finisate cu luciu oglindă de la autovehicule, pahare etc.

Suprafețele finisate cu luciu oglindă au un aspect nobil, fiind apreciate pe termen lung prin întregul lor design.

Dacă respectați aceste puține indicații privind întreținerea, va veți bucura mult timp de mobilierul dumneavoastră.

Ošetrovanie a čistenie povrchov s vysokým leskom

Na čistenie by ste mali používať výlučnemikrofázové handričky zľahka navlhčené vo vode. **Nesmú sa používať žiadne iné handričky!**



Všetky použité handričky musia byť čisté a nesmú obsahovať žiadne nečistoty, ako s? zrnka? piesku a prachu. Ináč m?že d?jsť k poškrabaniu povrchu.

Ak by mali používané handričky preš?van? alebo obdobn? okraj, je dôležité, aby ste týmto okrajom nevyvíjali žiaden tlak na povrch!

Zabudnite na používanie čistiacich prostriedkov!



Môžu vzniknúť mikroskopicky malé stopy po používaní, ktoré sú viac alebo menej viditeľné v závislosti od farby a dopadu svetla.

Stopy po používaní nepredstavujú žiadne zníženie hodnoty. Tak isto, ako aj pri ostatných povrchoch s vysokým leskom na autách, sklách atď. sa im z dlhodobého hľadiska nedá zabrániť.

Povrchy s vysokým leskom pôsobia ušľachtilo a dlhodobopresvedčajú o celkovom dizajne.

Ak budete dodržiavať týchto málo pokynov ohľadom ošetrovania, budete mať veľmi dlho radosť zo svojho nábytku.

Cuidados e limpeza de superfícies de alto brilho

Limpe sempre as superfícies com um pano de microfibras ligeiramente umedecido com água. **Não use nenhum outro tipo de pano!**



Certifique-se de que o pano usado esteja limpo e livre de contaminação, como poeira e areia, para evitar o arranhão das superfícies.

Se o pano usado para limpar as superfícies tem uma borda costurada ou borda semelhante, é importante não pressionar forte contra as superfícies com tal borda ou borda.

Não use agentes de limpeza!



Os agentes de limpeza podem deixar transações microscópicas na superfície que são mais ou menos visíveis dependendo das condições de cor e luz.

Os sinais de uso não prejudicam o valor, mas não podem ser evitados no longo prazo, assim como o caso com carros, óculos, etc.

A superfície de alto brilho tem um efeito sofisticado e proporciona um design atraente e duradouro.

Se você seguir essas poucas instruções de cuidados, você apreciará seus móveis nos próximos anos.

Nega in čišćenje površin z močnim leskom

Za čišćenje uporabljajte samo z vodo le malo navlaženo krpo iz mikrovlaknen. **Drugih krp se ne dopušča uporabljati!**



Vse krpe, ki jih uporabljate, morajo biti čiste in ne smejo vsebovati nesnage ali delcev, kot so zrnca prahu ali peska, ki bi lahko opraskala površino.

Če imajo uporabljene krpe prišit ali podoban rob, je pomembno, da z njim ne pritisnete na površino!

Ne uporabljajte čistil!



Pri uporabi čistil bi lahko nastale mikroskopsko majhne sledi uporabe, ki so glede na barvo in vpad svetlobe lahko bolj ali manj vidne.

Sledi uporabe ne predstavljajo zmanjšanja vrednosti uporabe, temveč jih, kot pri vseh močno lesketajočih se površinah na avtih, kozarci itd. dolgotrajno ni mogoče preprečiti.

Močno lesketajoče se površine imajo plemeniti izgled in dolgotrajno prevladujejo pri dizajnu.

Če boste upoštevali teh par nasvetov, vam bo vaše pohištvo dolgo v veselje.







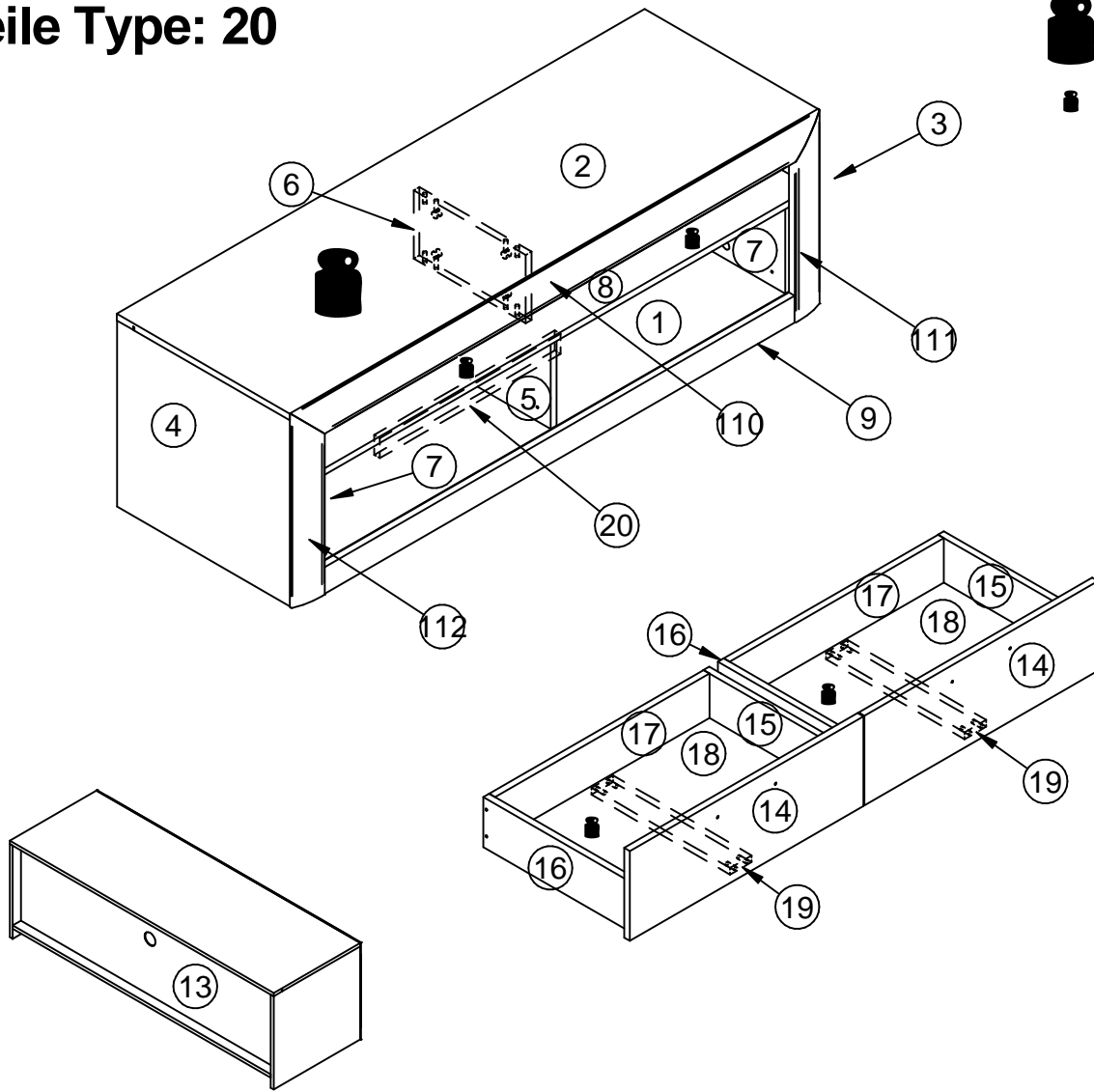

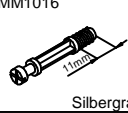

Bauteile Type: 20

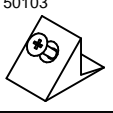
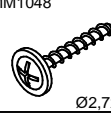
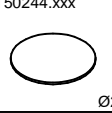
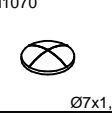
 max. 40kg

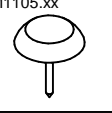
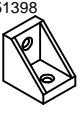
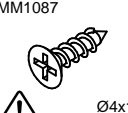
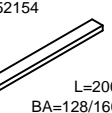

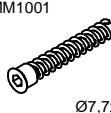
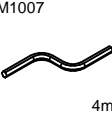
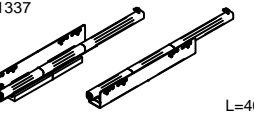
 max. 5kg

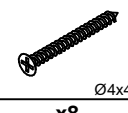
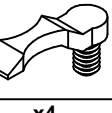

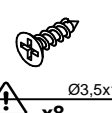
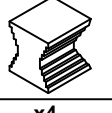
Beschlagteile Type: 20

BT1016  x20	MM1016  Silbergrau 11mm x24	MM1121  Ø8x30 x46	BT50103  x4	MM1048  Ø2,7x20 x9	BT50244.xxx  Ø20 x10	MM1070  Ø7x1,5 x4	BT1121  x1	MM1105.xx  x6
BT51398  x18	MM1087  ! Ø4x15 x36	BT52154  L=200 BA=128/160 x2	MM1033  Ø4x27 x4	MM1001  Ø7,7x45 x6	MM1007  4mm x1	BT1337  L=400 x2		
MM1188  Ø6,3x9 x8	MM1021  Ø4x40 x8	BT51326  x4	BT1015  mit Rand x4	BT1182.xx  Ø60 x1	MM1046  ! Ø3,5x13 x8	MM50464  x4		

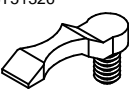
1.

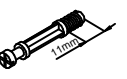
BT51326 	MM1121 	BT1015 	MM1016 
x4	Ø8x30 x16	mit Rand x4	Silbergrau x4

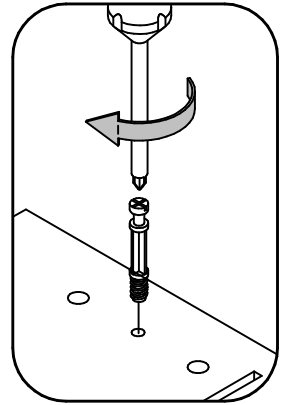
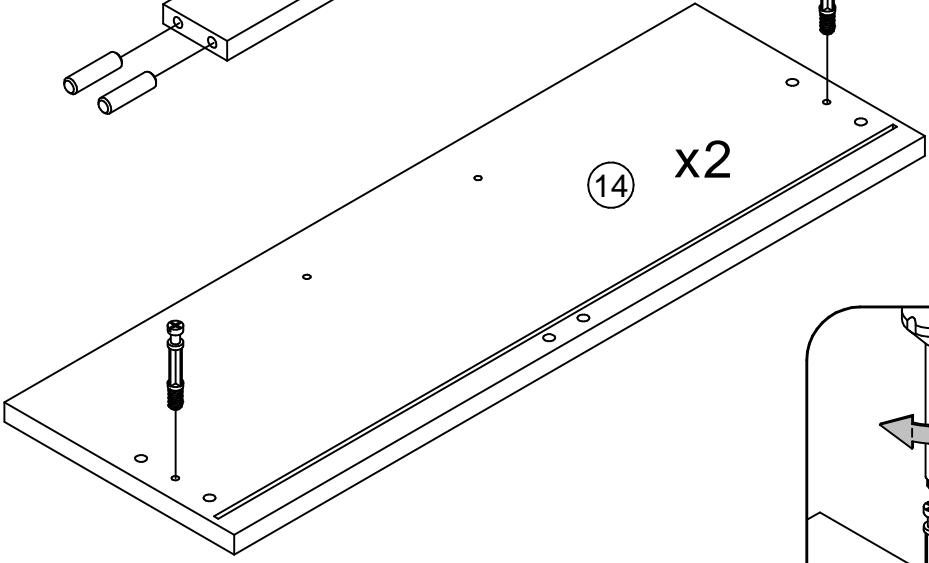
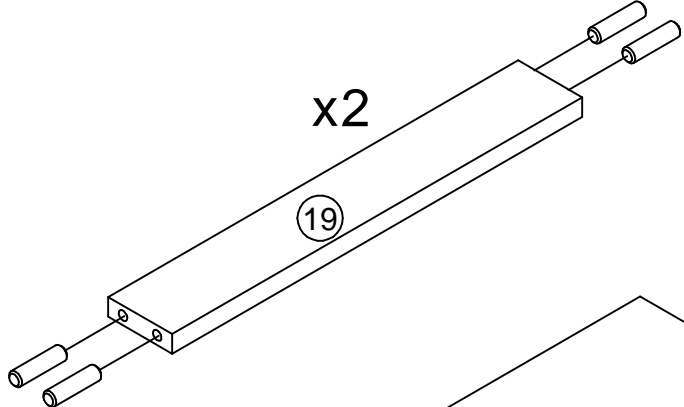
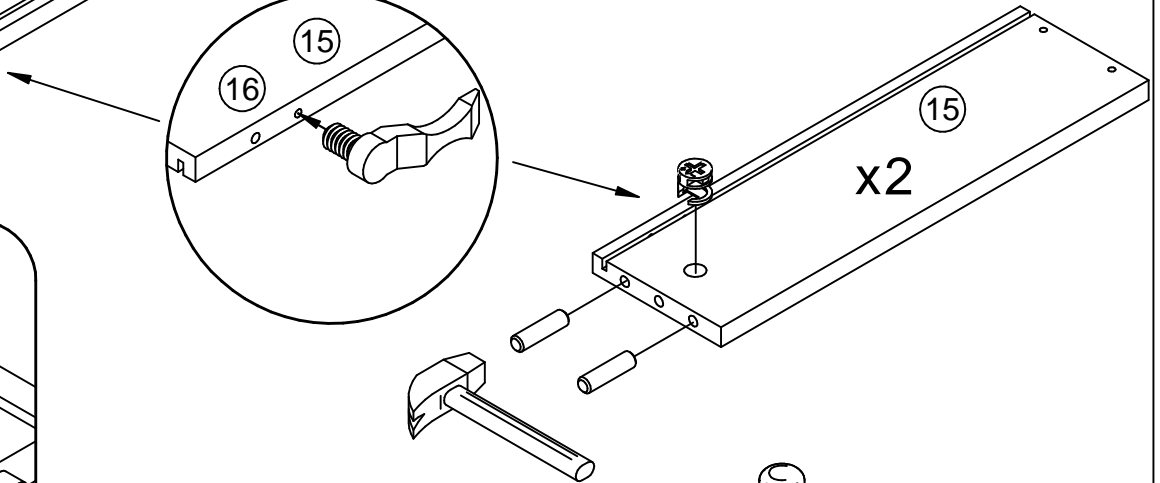
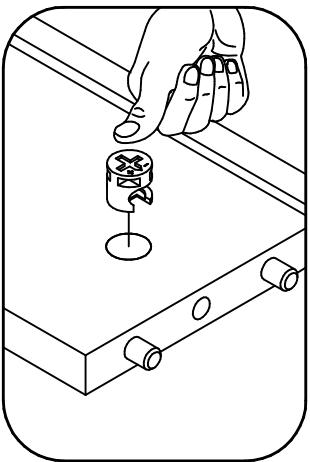
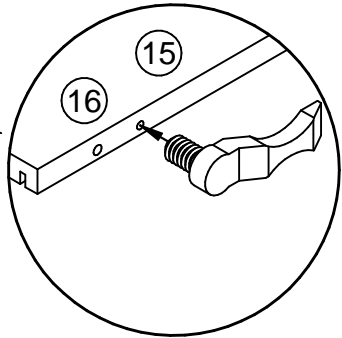
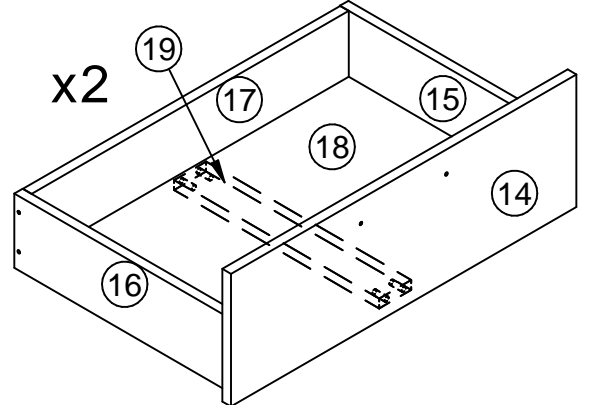
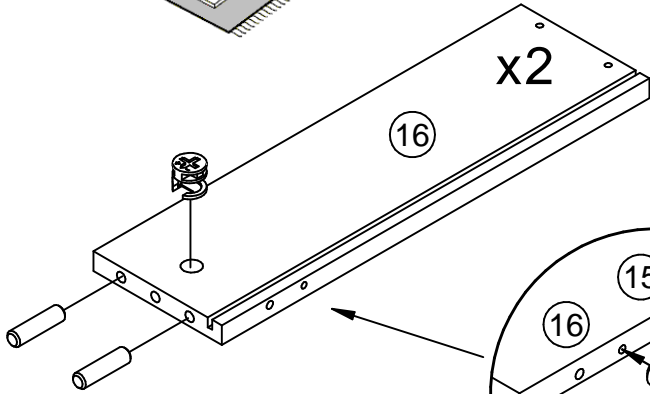
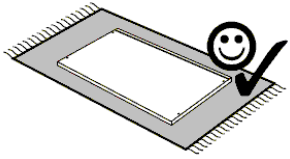

2.

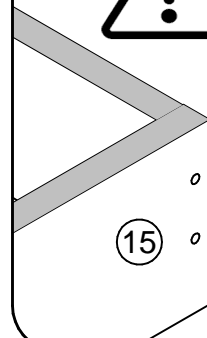
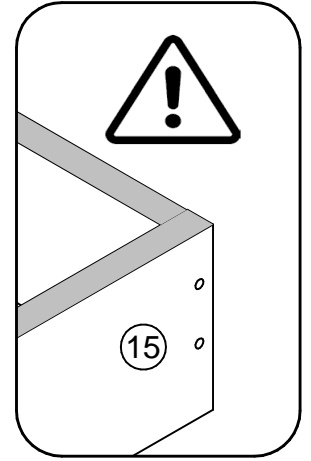
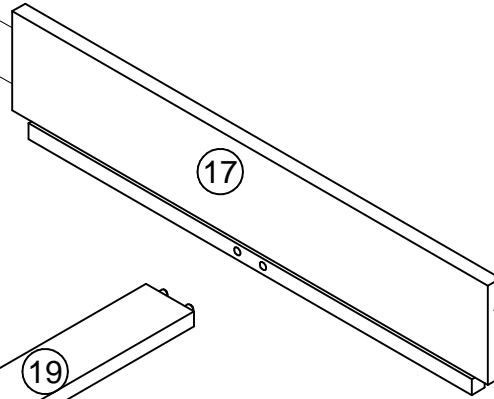
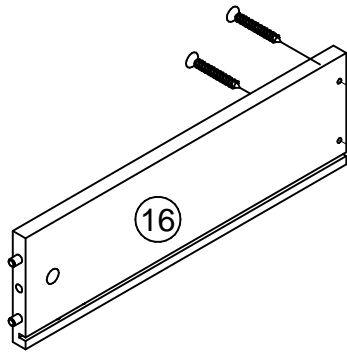
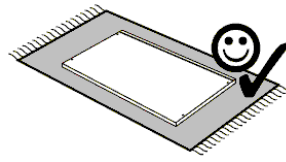
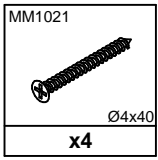

3.

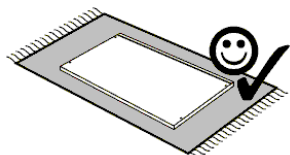
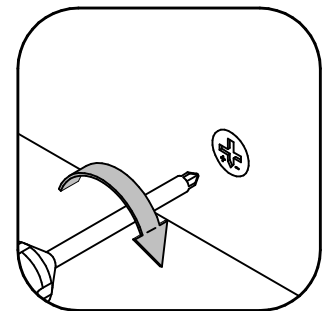
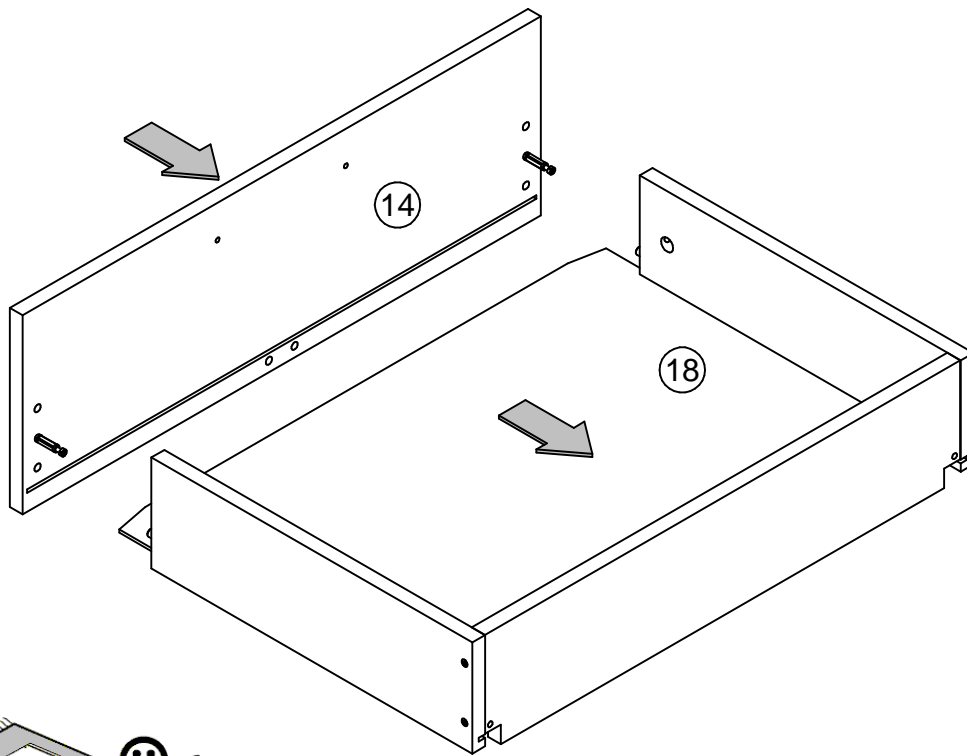
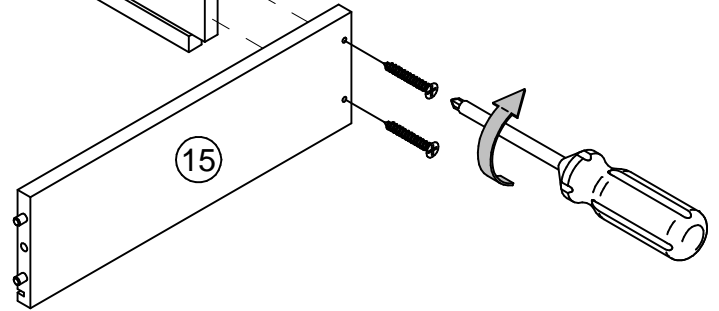
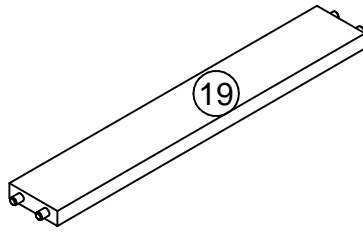

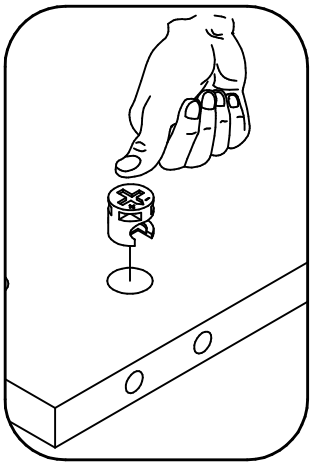
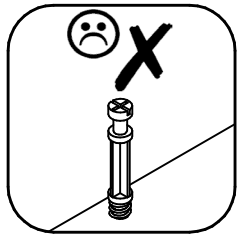
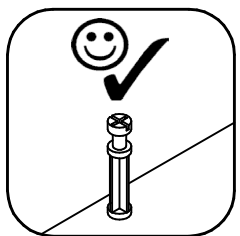
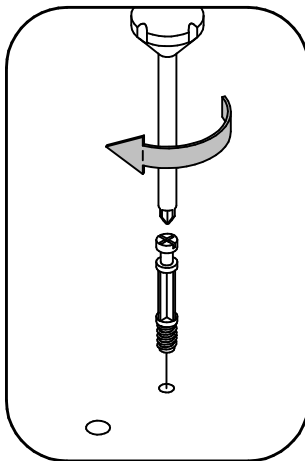
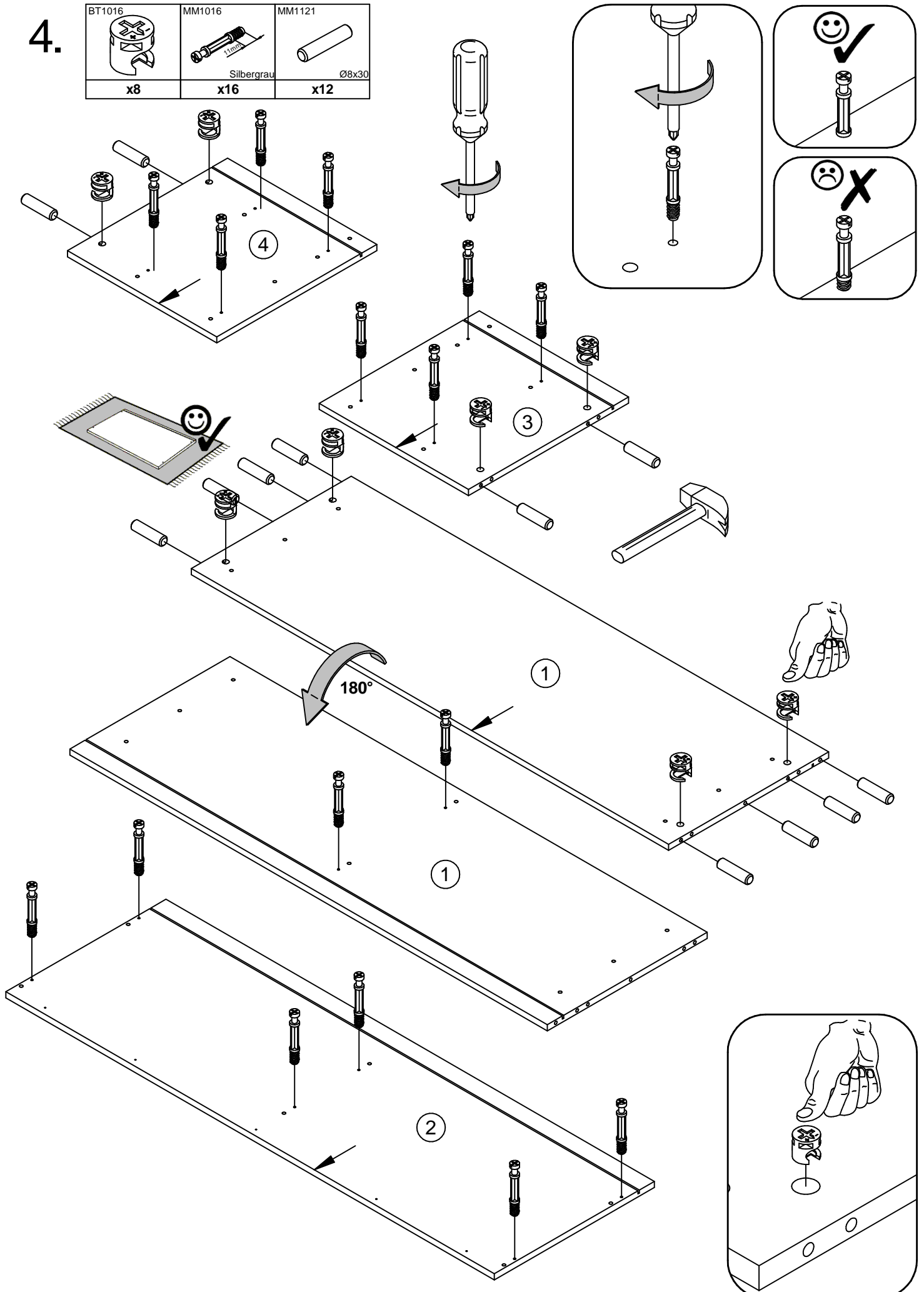

4.

BT1016  x8	MM1016 1mm Silbergrau x16	MM1121 Ø8x30 x12
--	------------------------------------	------------------------



5.

BT1016  x12	MM1016  Silbergrau x2
MM1121  Ø8x30 x18	

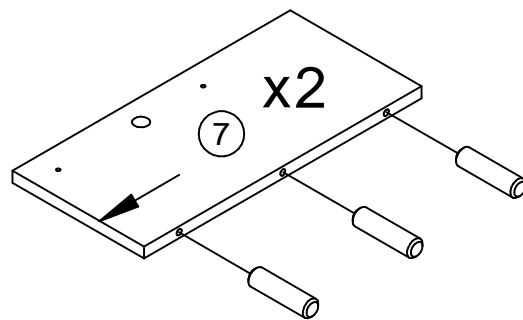
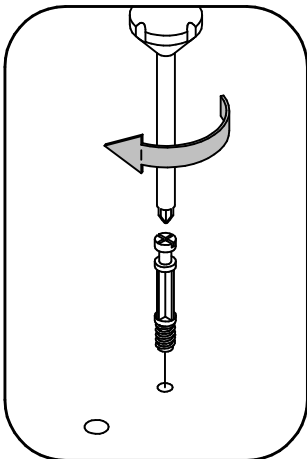
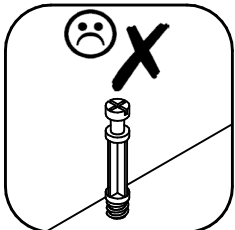
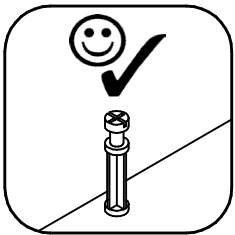
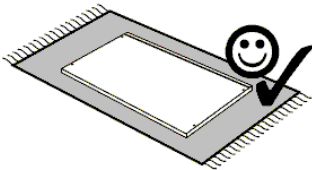
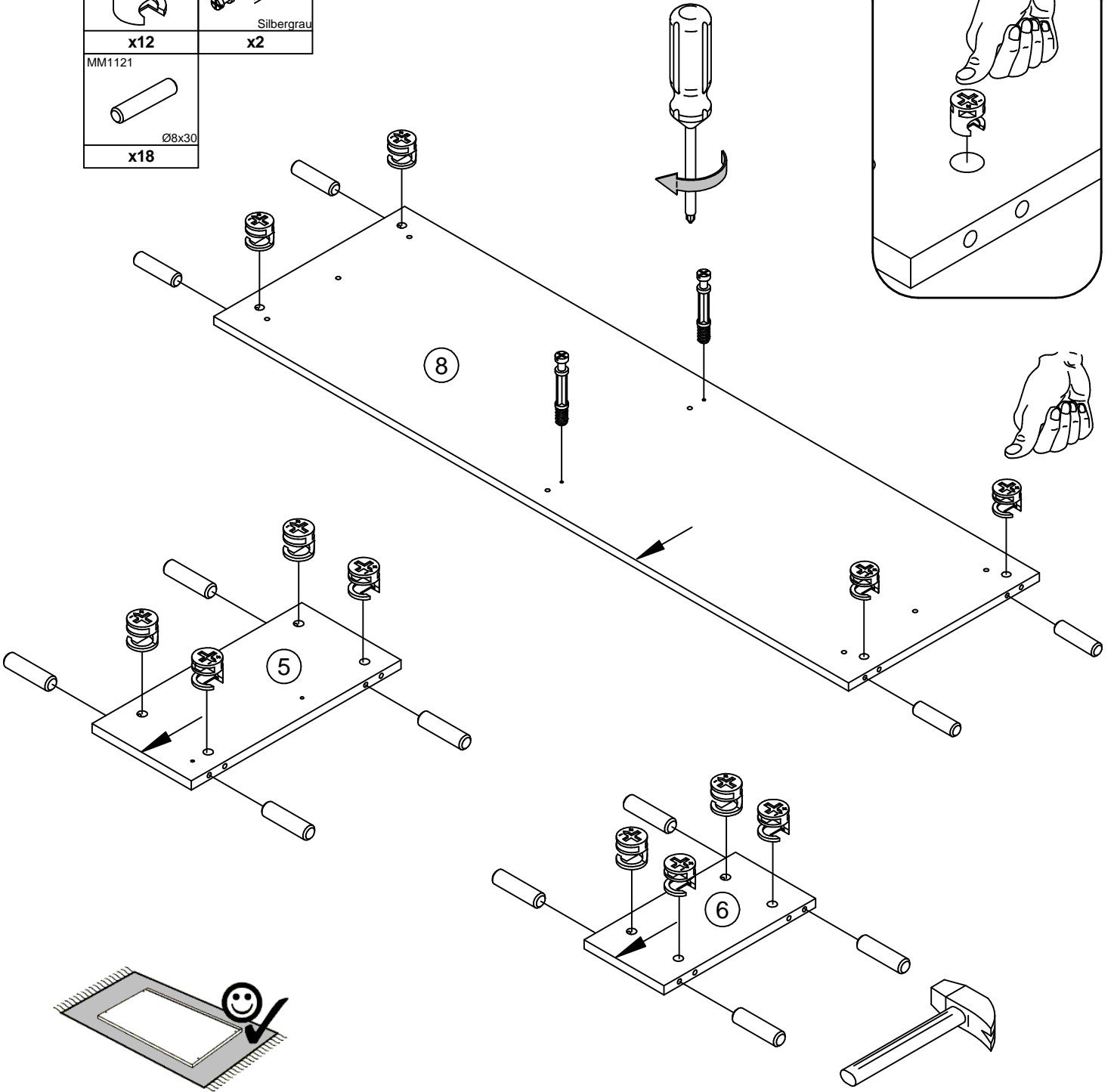

6.

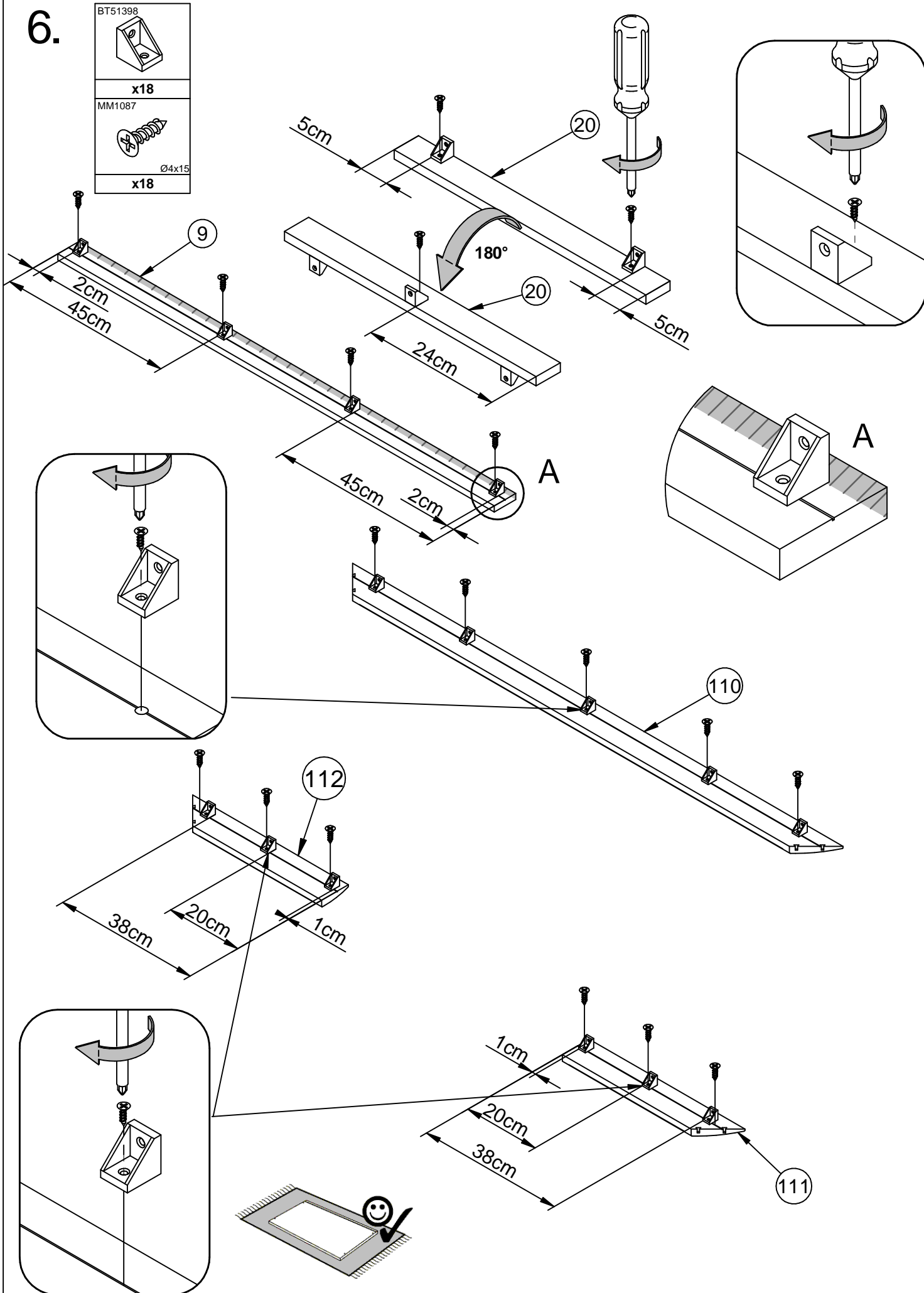
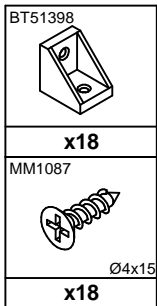

7.

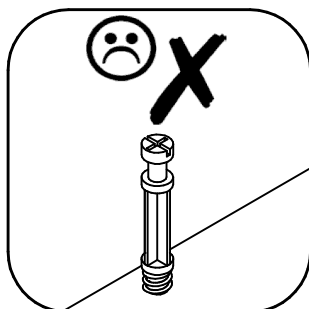
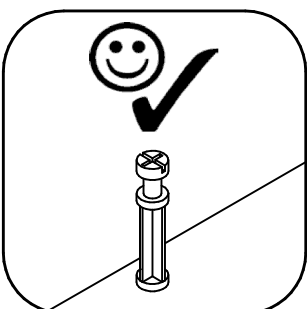
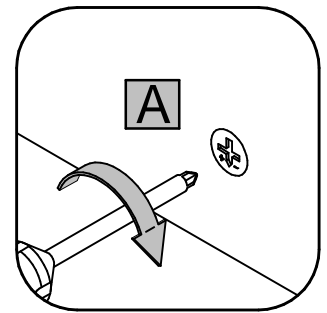
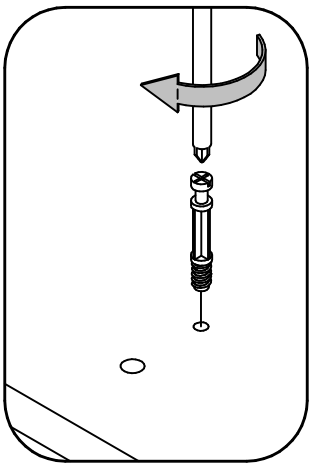
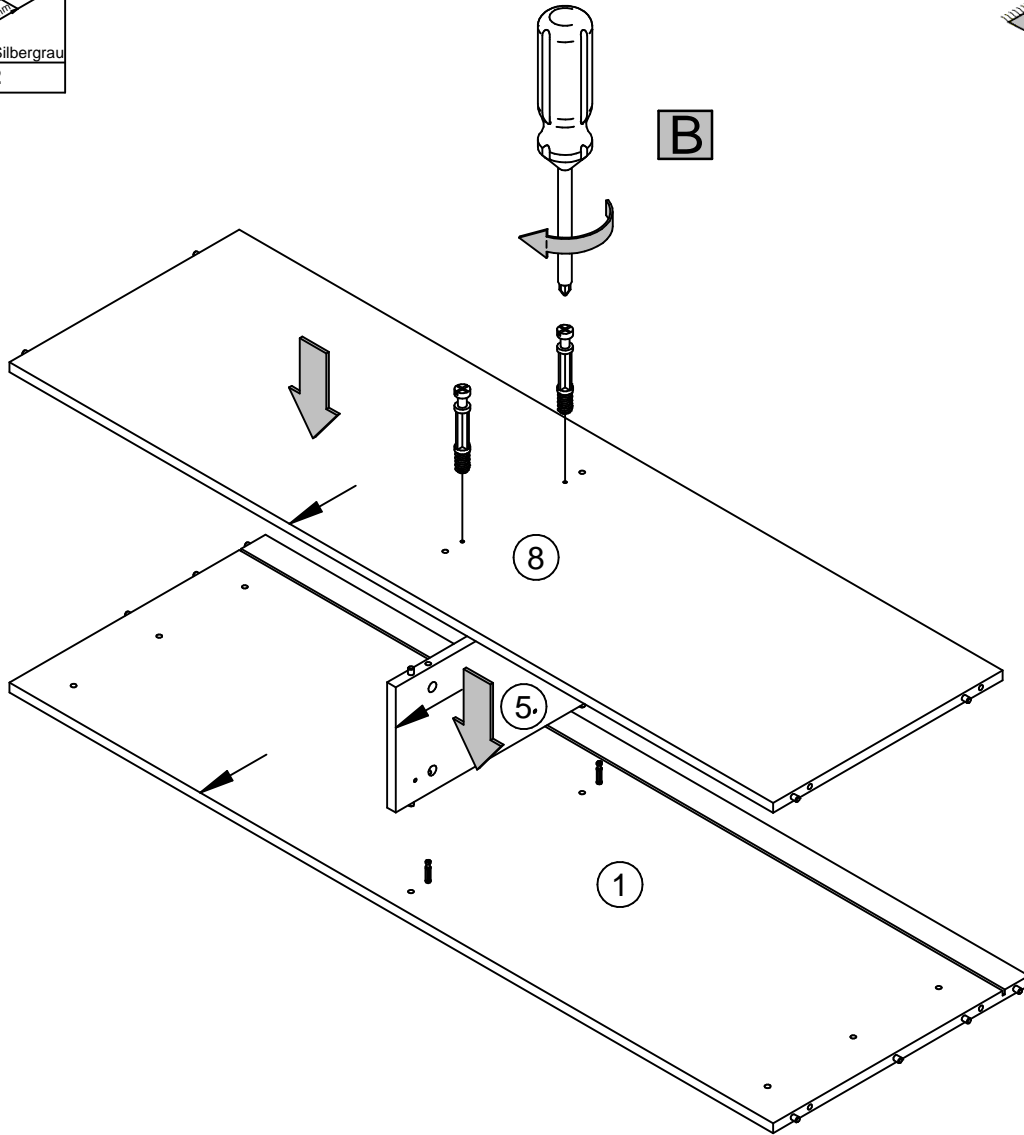
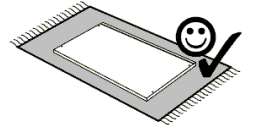
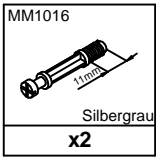

8.

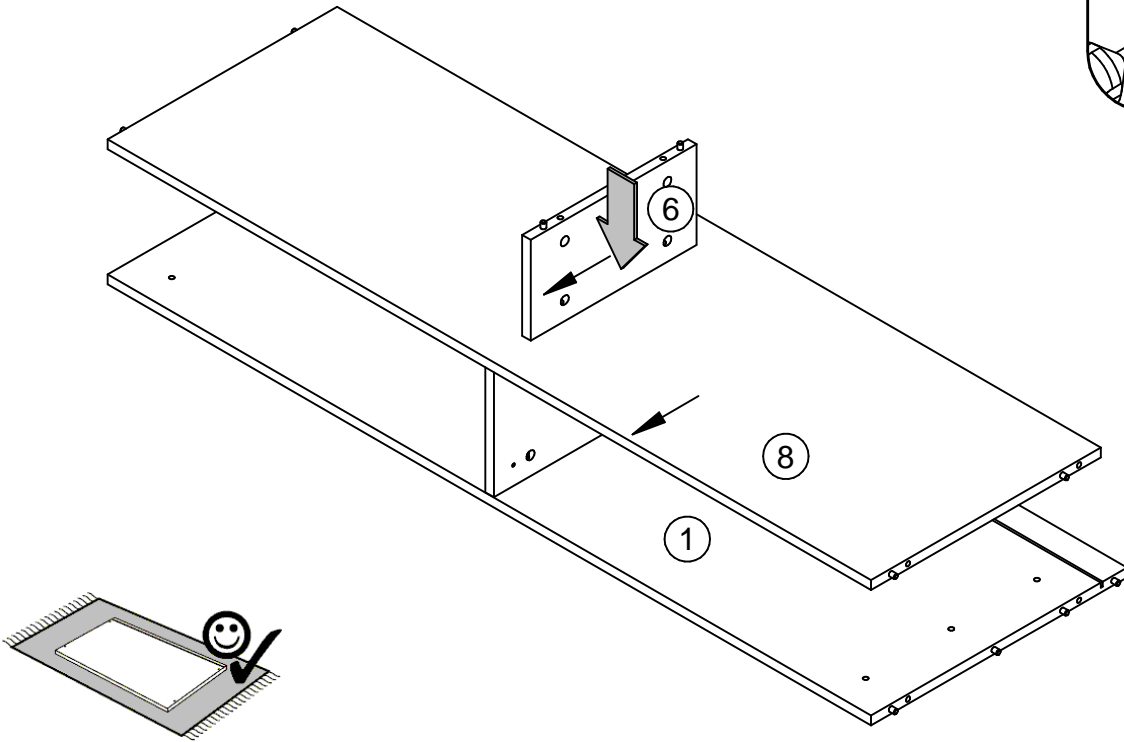
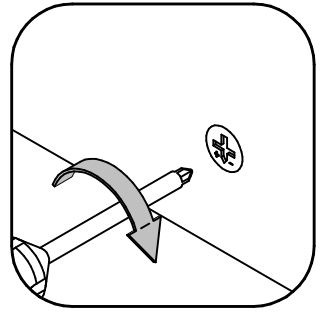

9.

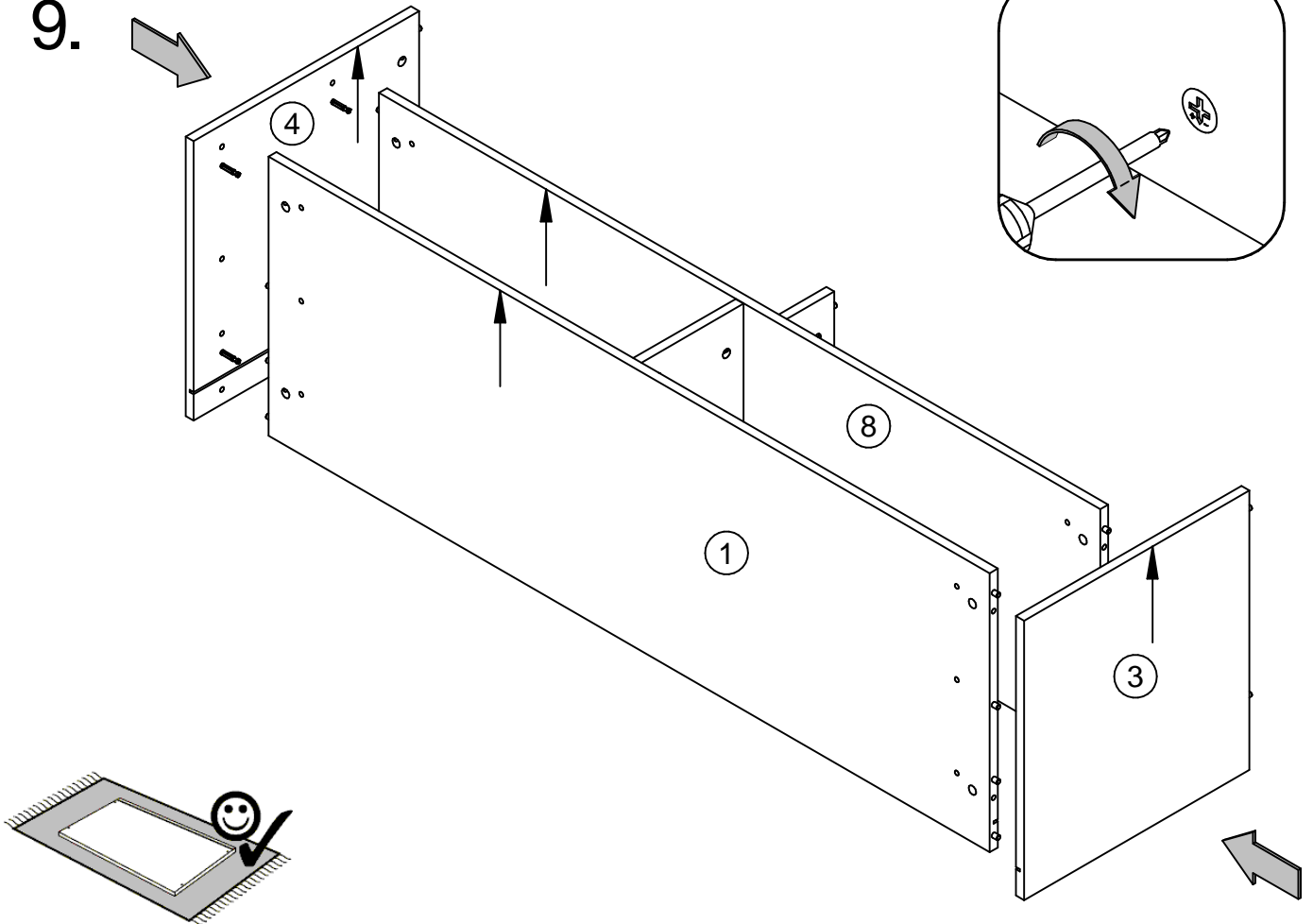
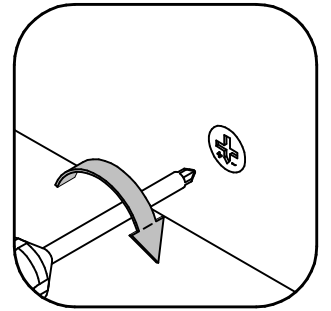

10.

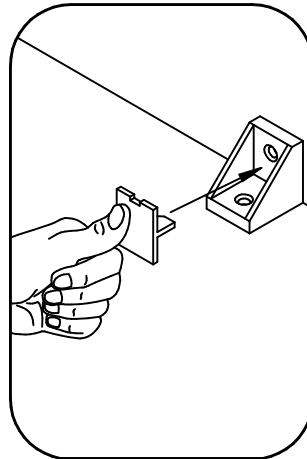
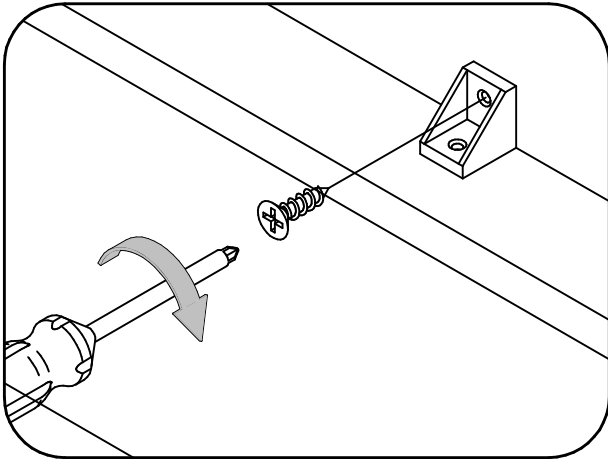
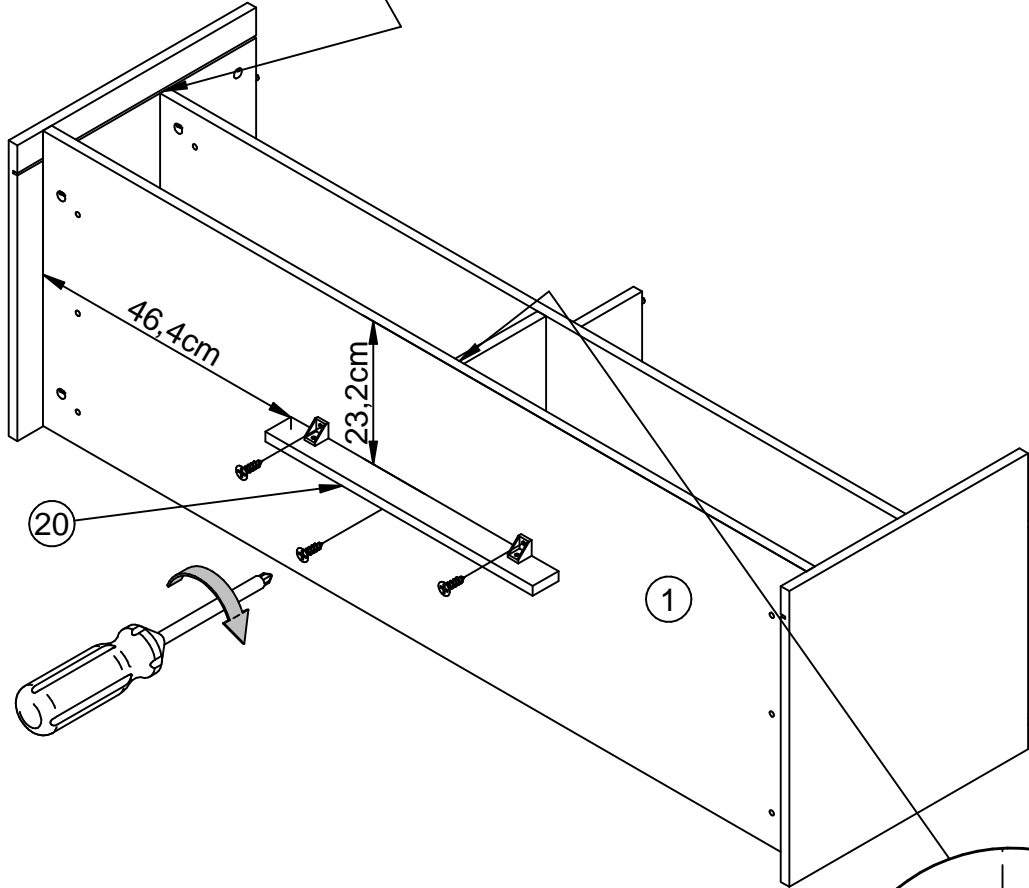
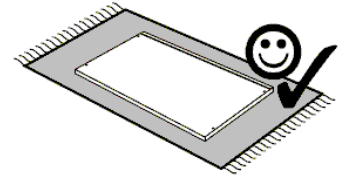
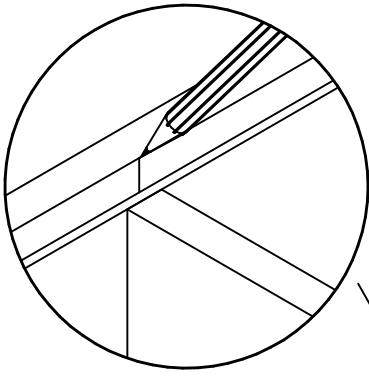
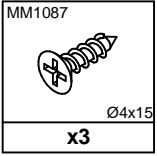

11.

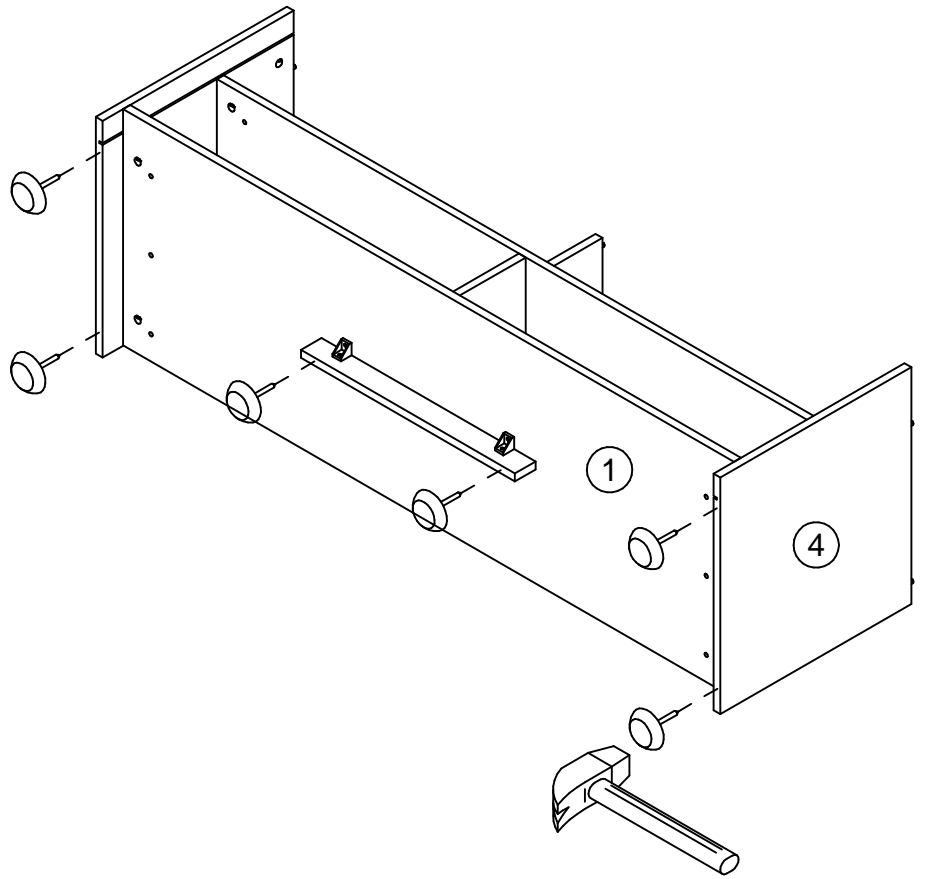
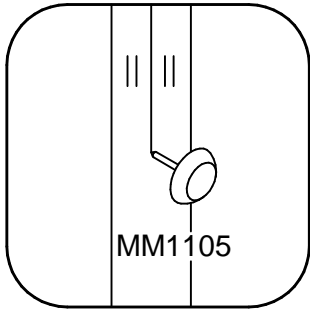
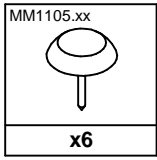

12.

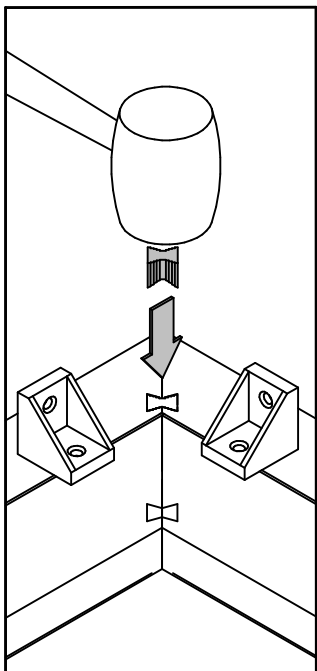
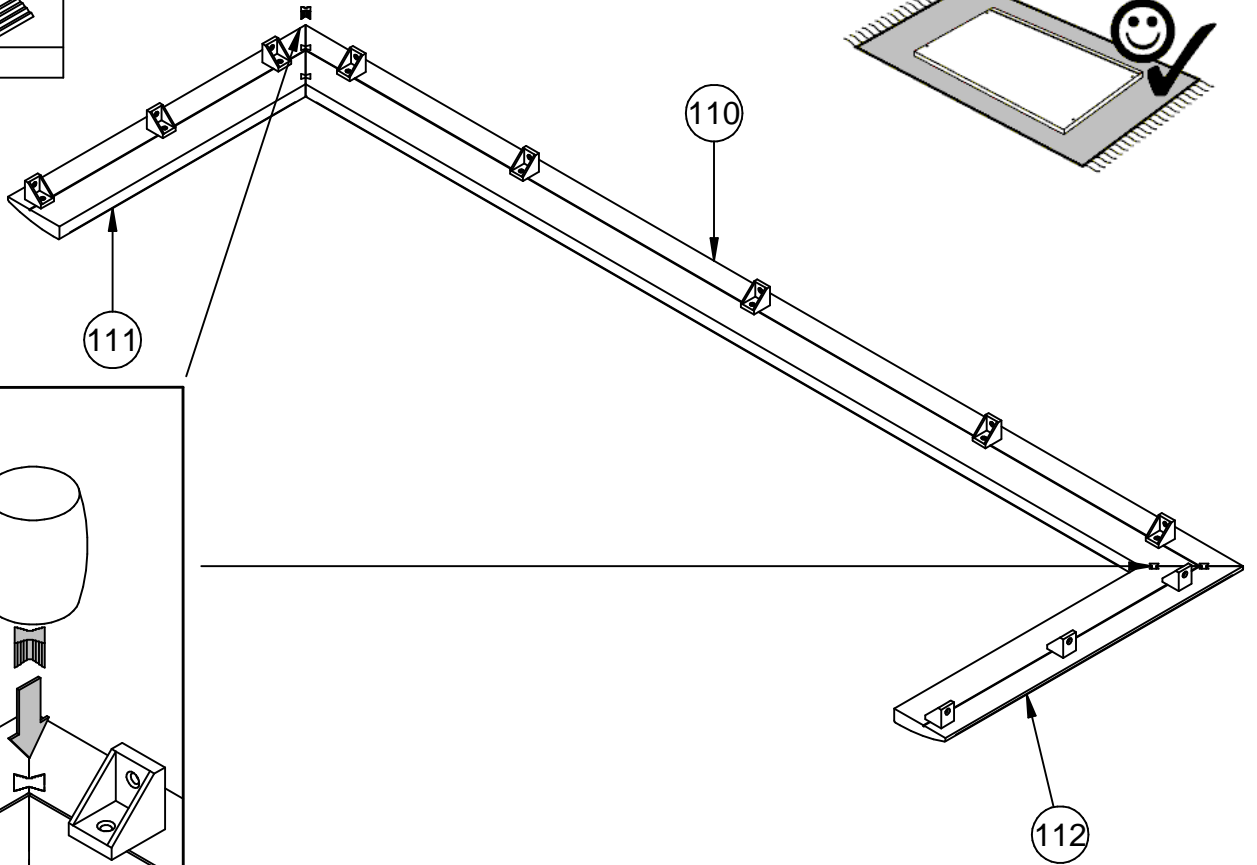
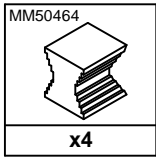

13.

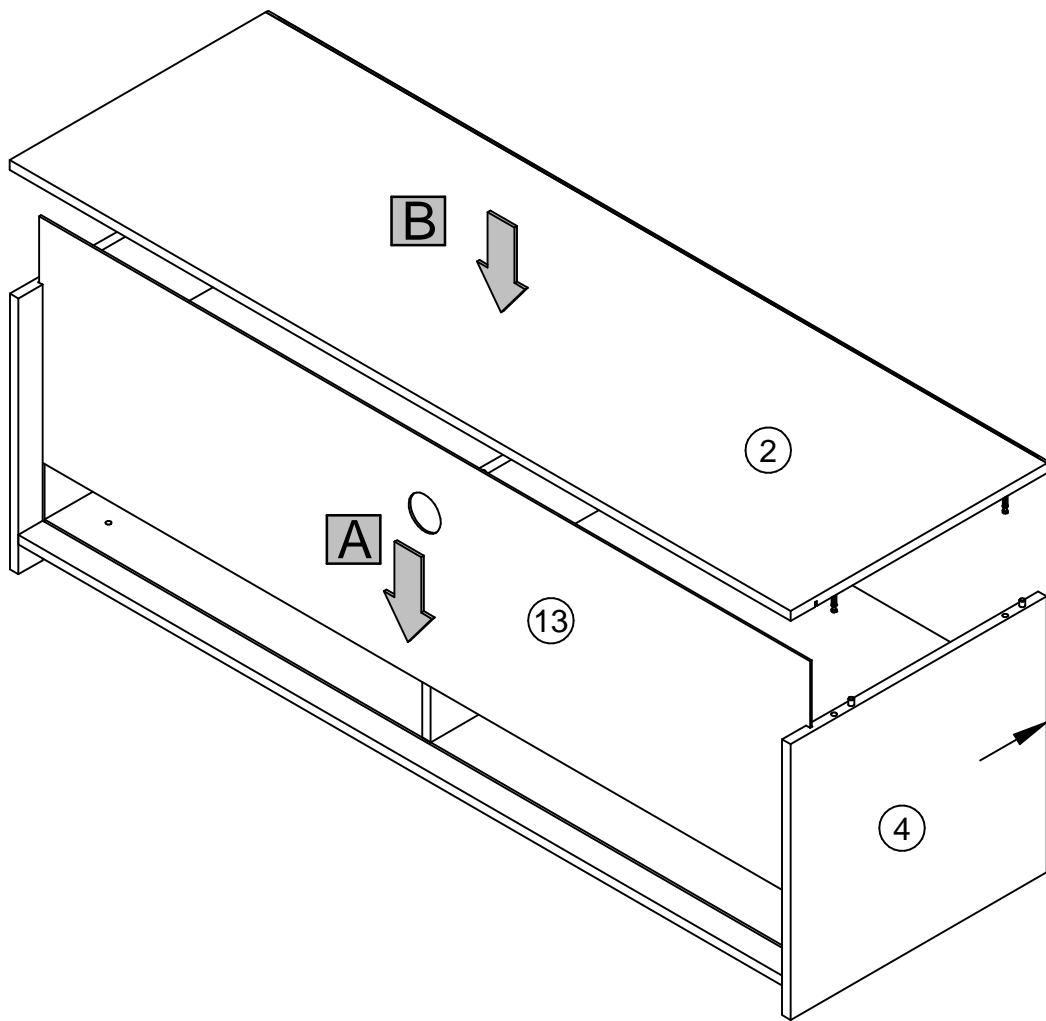
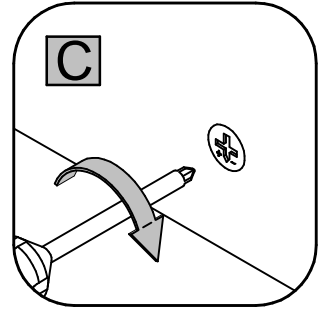

14.

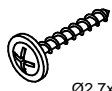

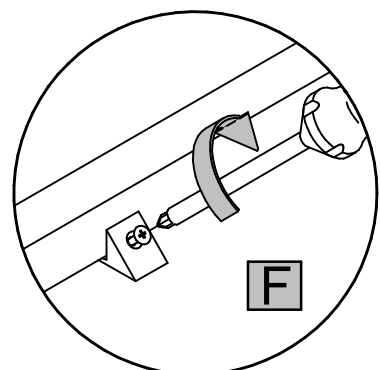
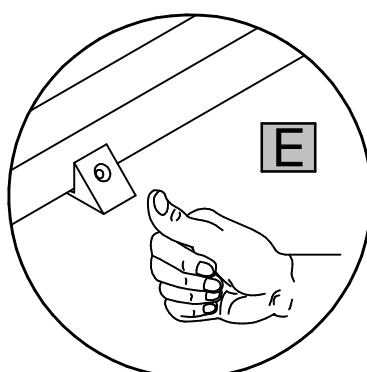
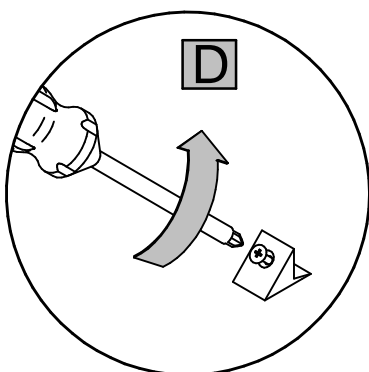
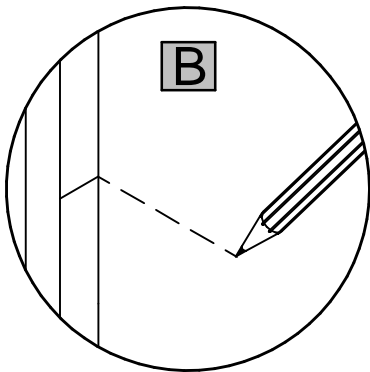
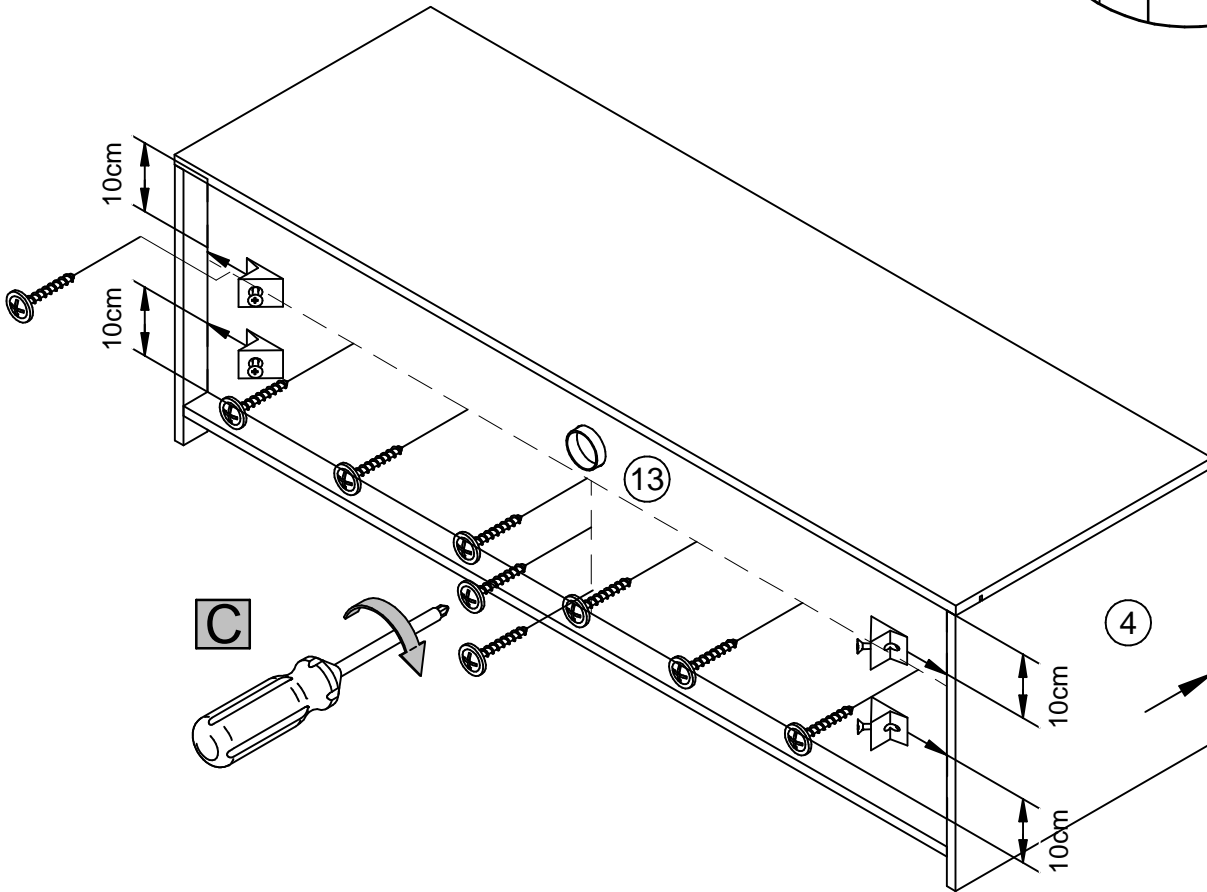
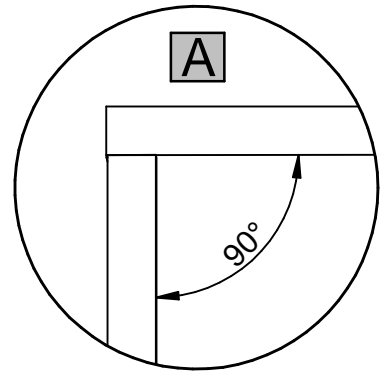
BT50103 	MM1048  Ø2,7x20
x4	x9

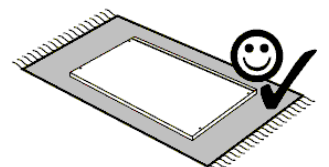
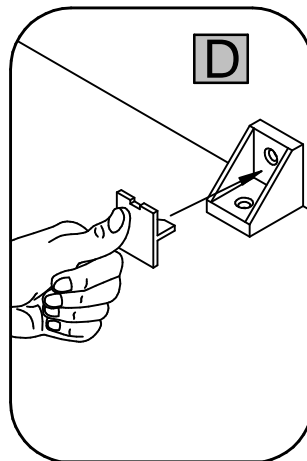
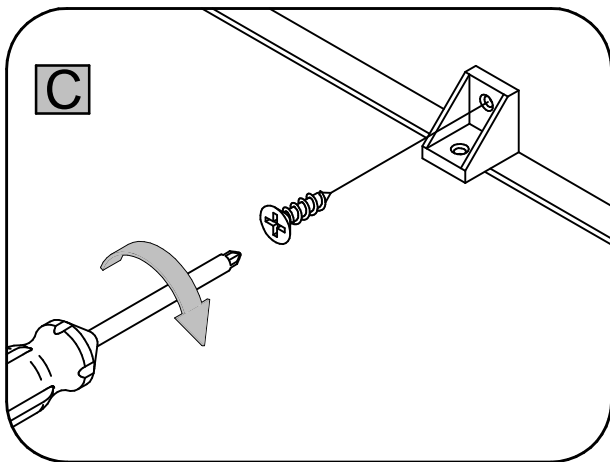
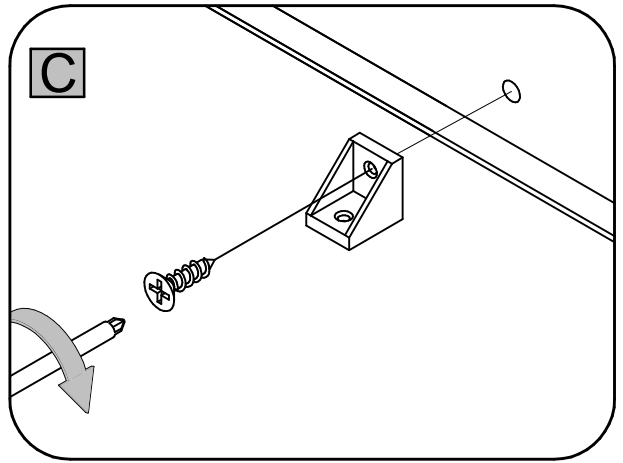
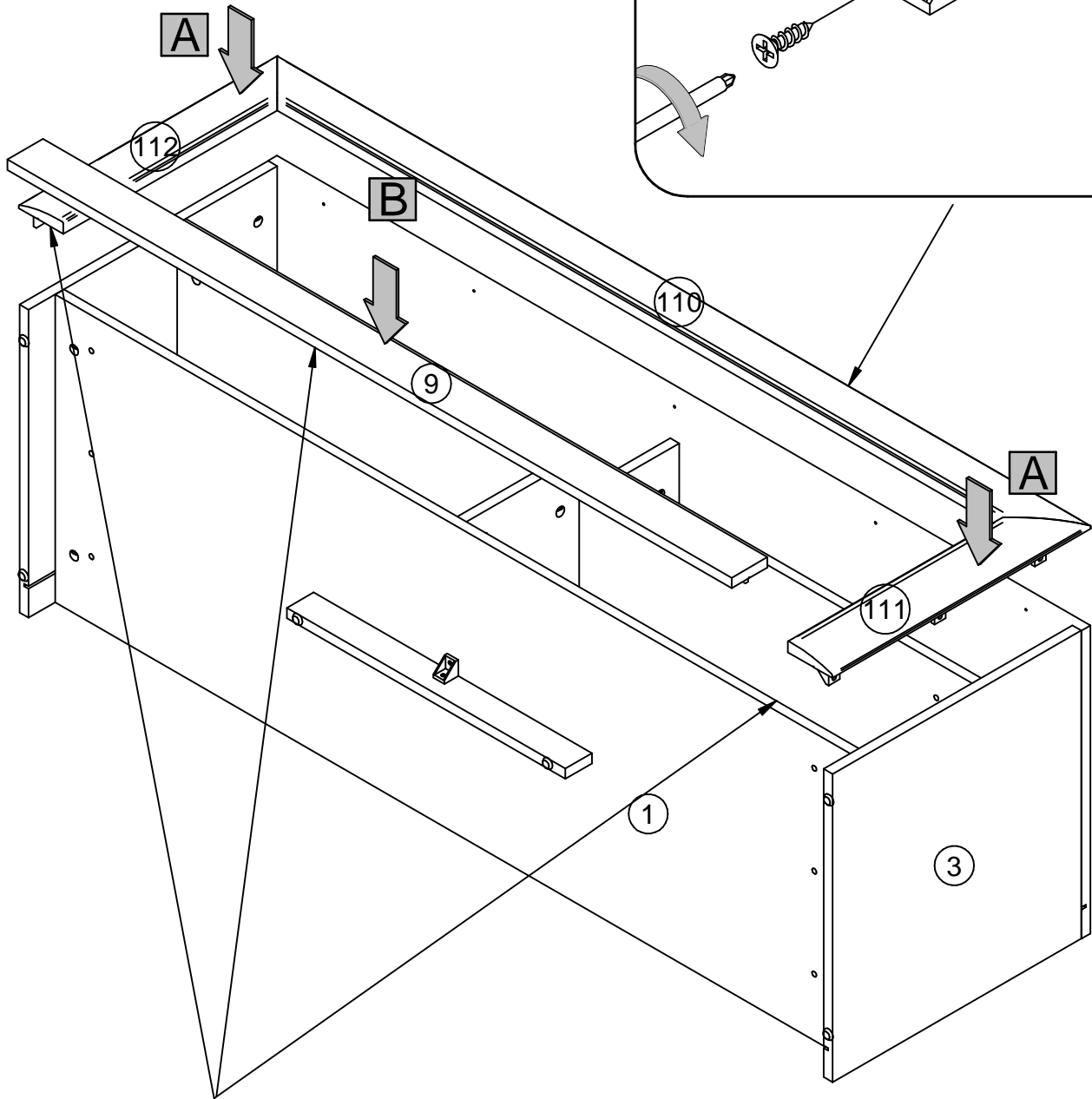
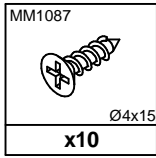

15.





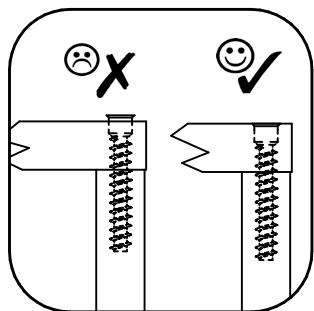
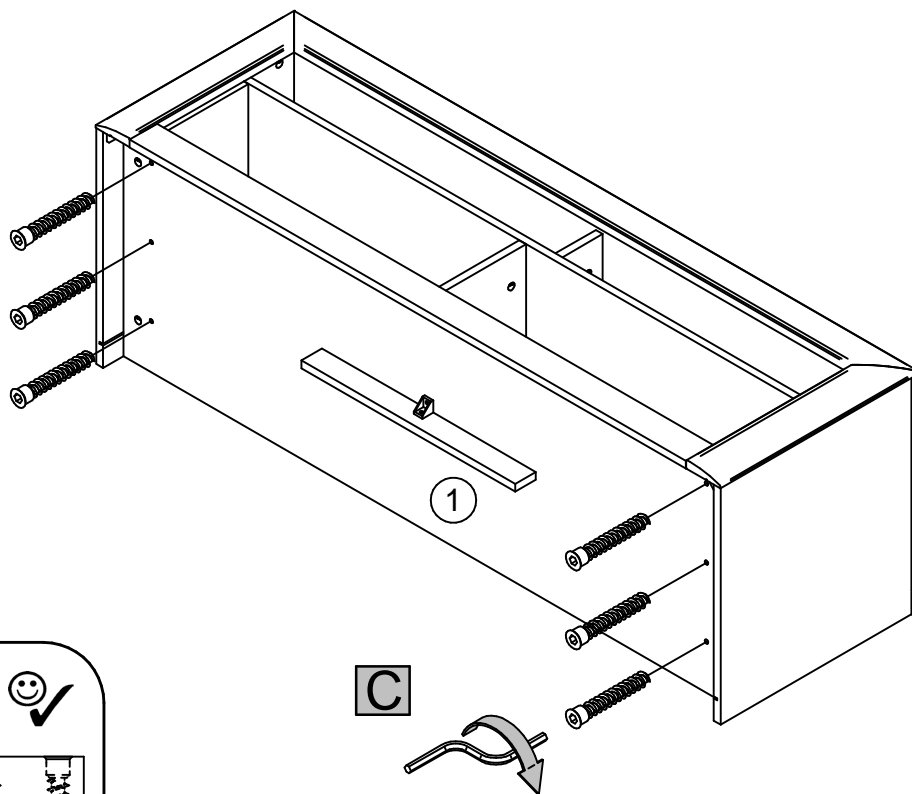
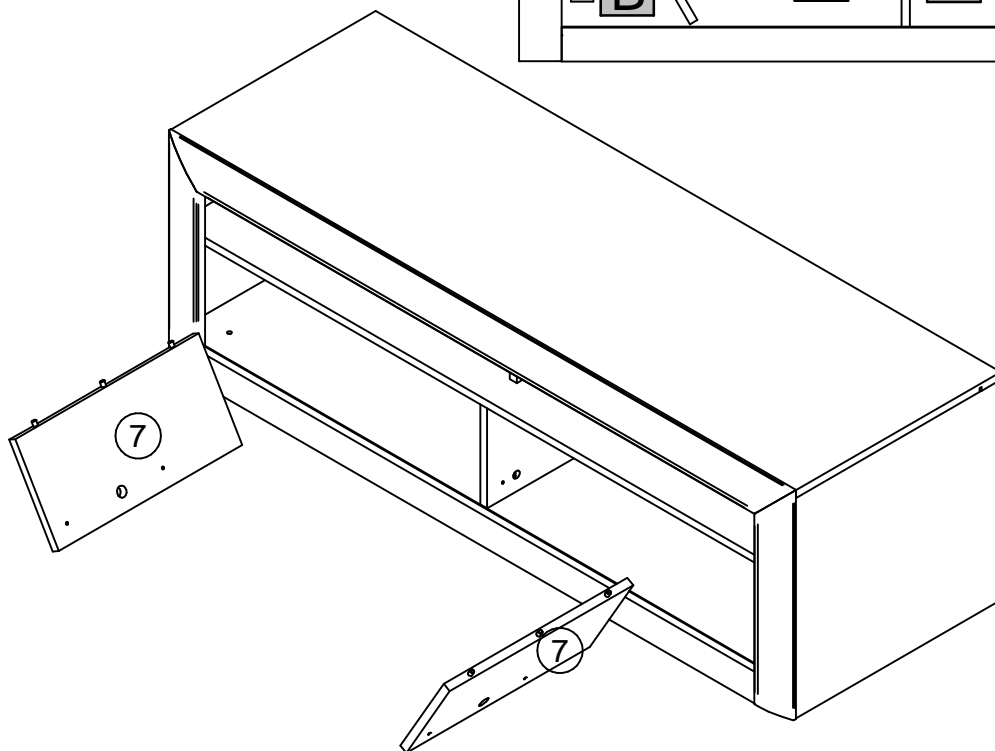
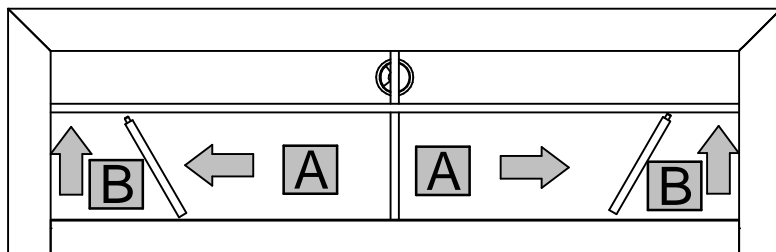

16.

MM1001	MM1007
	
Ø7,7x45	4mm
x6	x1

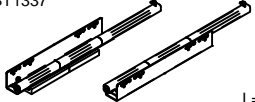

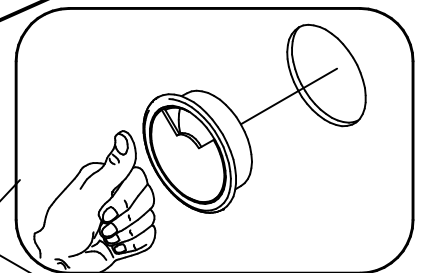
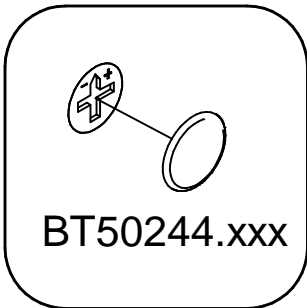
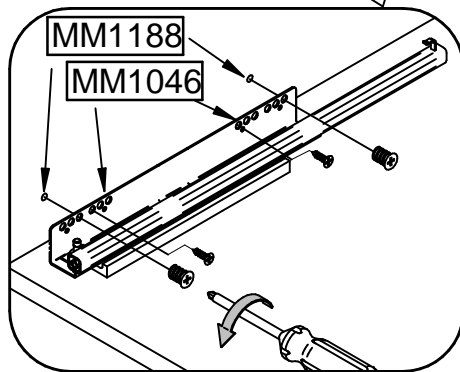
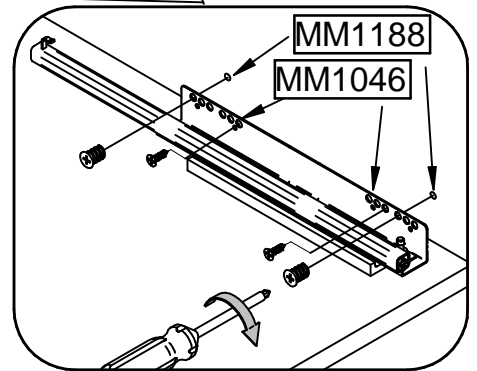
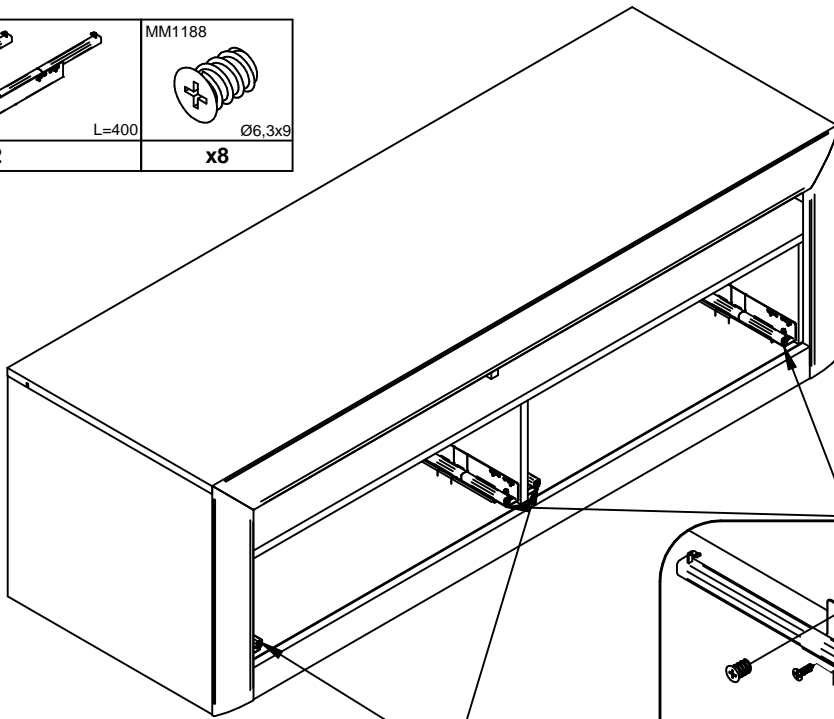

17.

BT1337  L=400 x2	MM1188  Ø6,3x9 x8
MM1046  Ø3,5x13 x8	
BT50244.xxx  Ø20 x10	



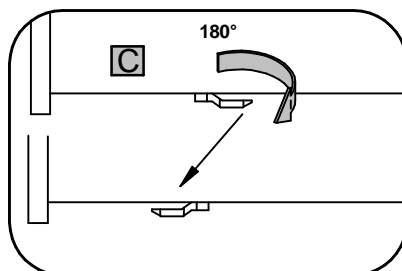
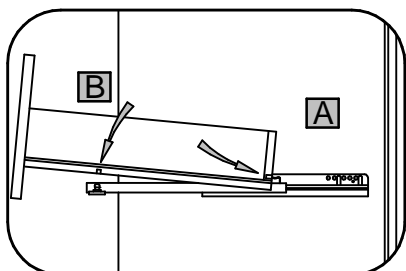
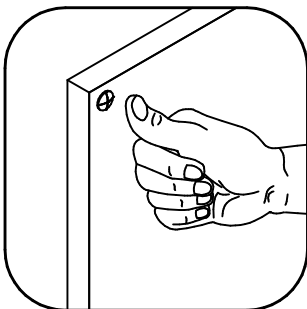
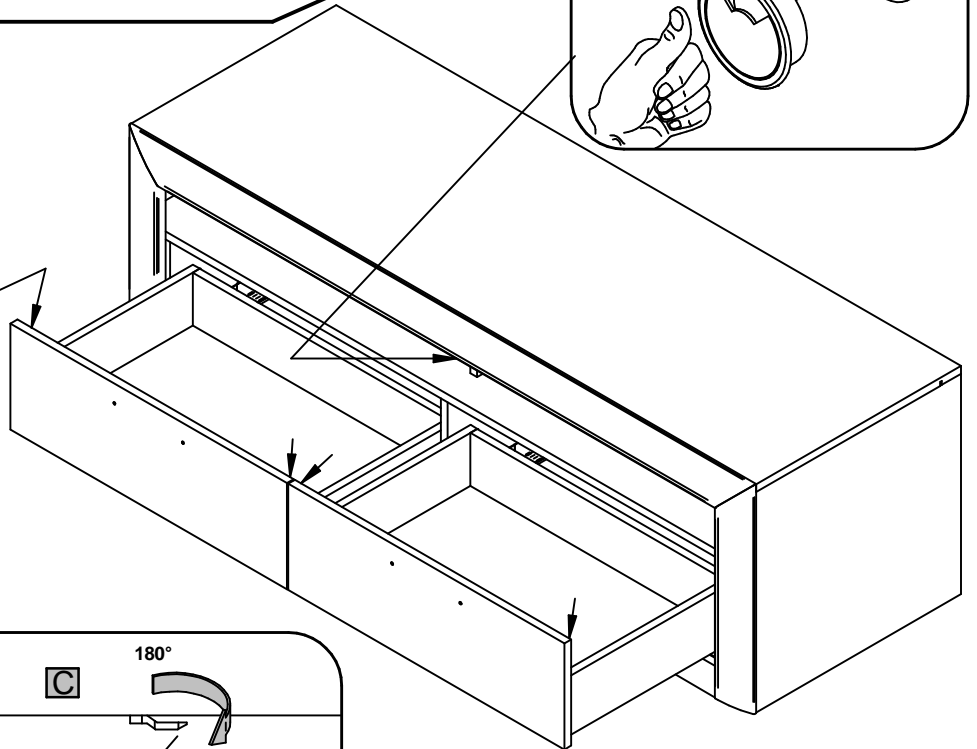

18.

MM1070  Ø7x1,5 x4	BT1182.xx  Ø60 x1
--	--

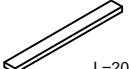

19.

BT52154  L=200 BA=128/160 x2	BT51419  Intra L=200 BA=128/160 x2	MM1033  Ø4x27 x4
--	---	---

oder

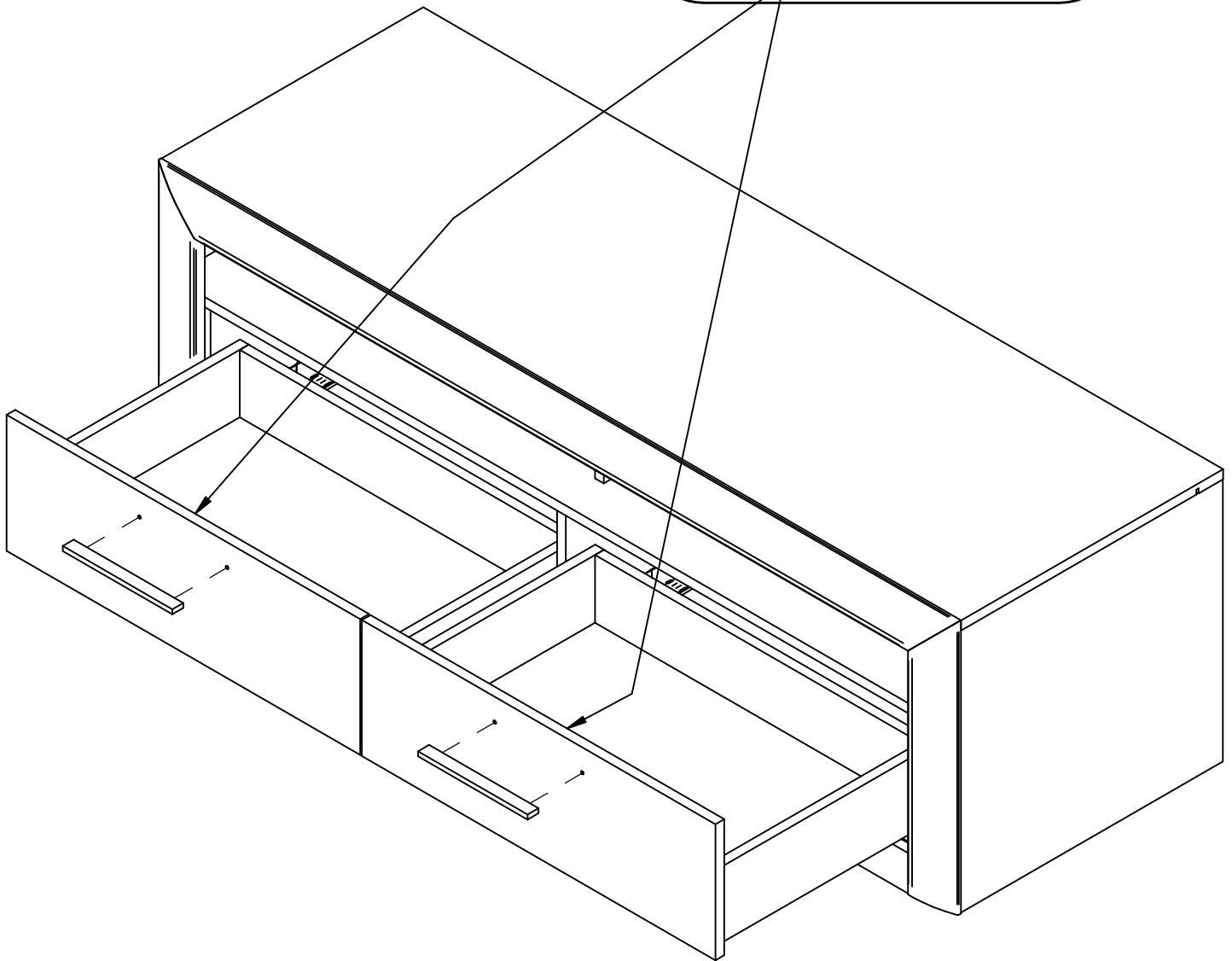
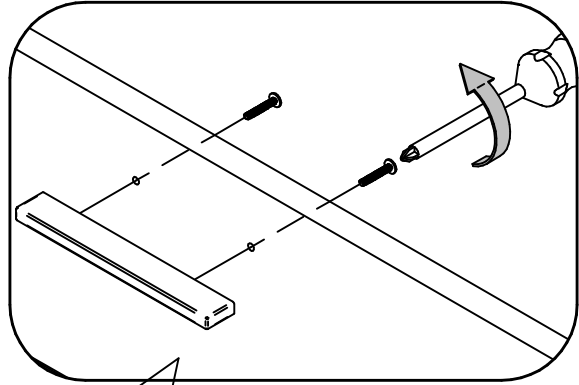

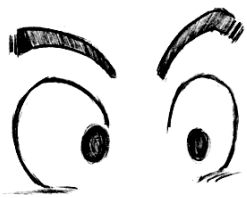



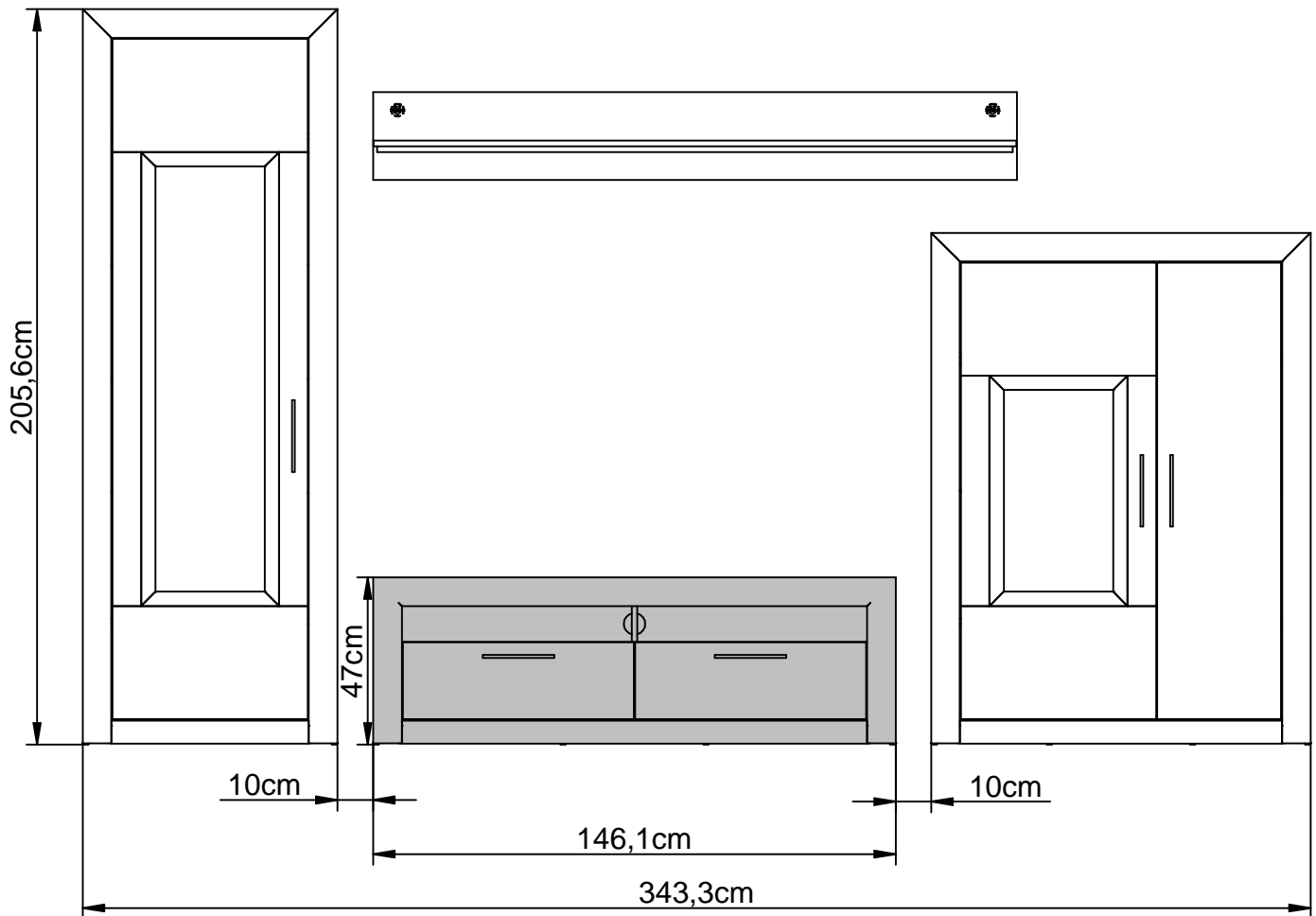

Kombination 1

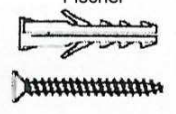
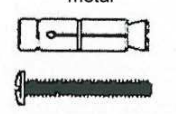
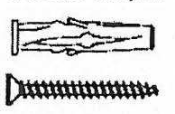
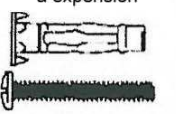

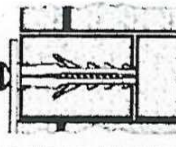
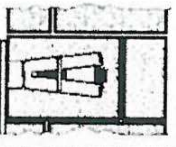

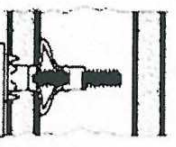
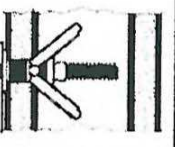

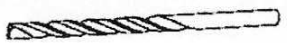
Il existe une grande diversité de types de murs ou cloisons, c'est la raison pour laquelle nous ne pouvons vous fournir le type exacte de fixation. Il est nécessaire d'identifier le type de paroi à laquelle vous allez fixer ce produit afin de vous procurer les fixations appropriées. Voici quelques exemples de fixation conseillées pour:

LES MURS PLEINS		LES CLOISONS CREUSES		
Cheville nylon "Fischer" 	Cheville d'ancrage metal 	Cheville d'ancrage a ailettes en nylon 	Cheville metallique a expansion 	Cheville "Molly" 
				

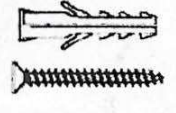
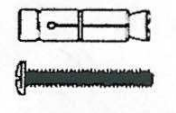
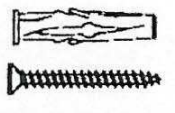
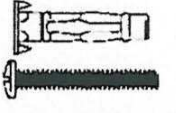
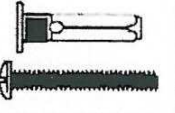
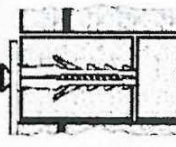
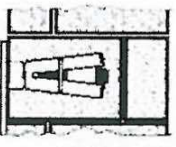

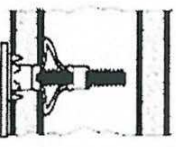
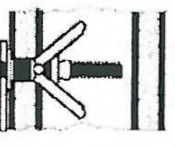

 Utiliser une taille de forêt adaptée à la quincaillerie utilisée et au type de mur.

Due to the wide diversity of wall or partition types, we cannot provide you with suitable attachment fixtures. To determine which attachment fixtures to use, you will need to identify the type of wall to which you will be fixing this product. Here are some examples of attachment fixtures recommended for:

BLIND WALLS		STUDDED WALLS		
"FISCHER" Nylon plug 	Metal Wall plug 	Nylon winged Wall plug 	Metal expansion plug 	"MOLLY" plug 
				

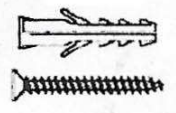
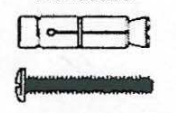
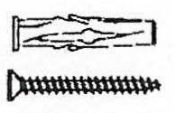
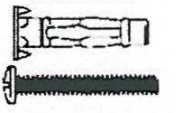
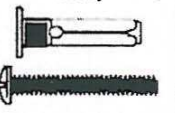
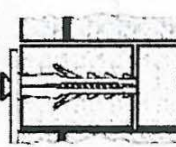
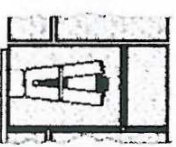

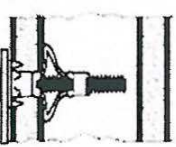
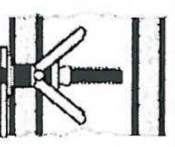
 Use a drill bit that is compatible in size with the hardware used and the type of wall.

Da es eine große Vielfalt an Arten von Wänden oder Trennwänden gibt, können wir Ihnen leider keine Wanddübel zur Verfügung stellen. Bitte prüfen Sie die Eigenschaft der Wand, an der Sie das Möbelstück befestigen wollen, um den dafür passenden Wanddübel zu ermitteln. Ziehen sie ggf. eine Fachkraft zurate. Hier einige Beispiele für Wände und dafür passende Dübel:

Massivwände		Hohlwände		
Kunststoffdübel 	Metall Wanddübel 	Hohlraum Kunststoffdübel 	Hohlraum Metalldübel 	Hohlraumdübel "Molly" 
				

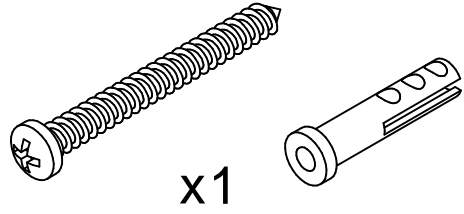
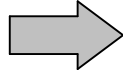

 Verwenden Sie einen an die Wandbeschaffenheit und Dübelgröße angepassten Bohrer.

20.

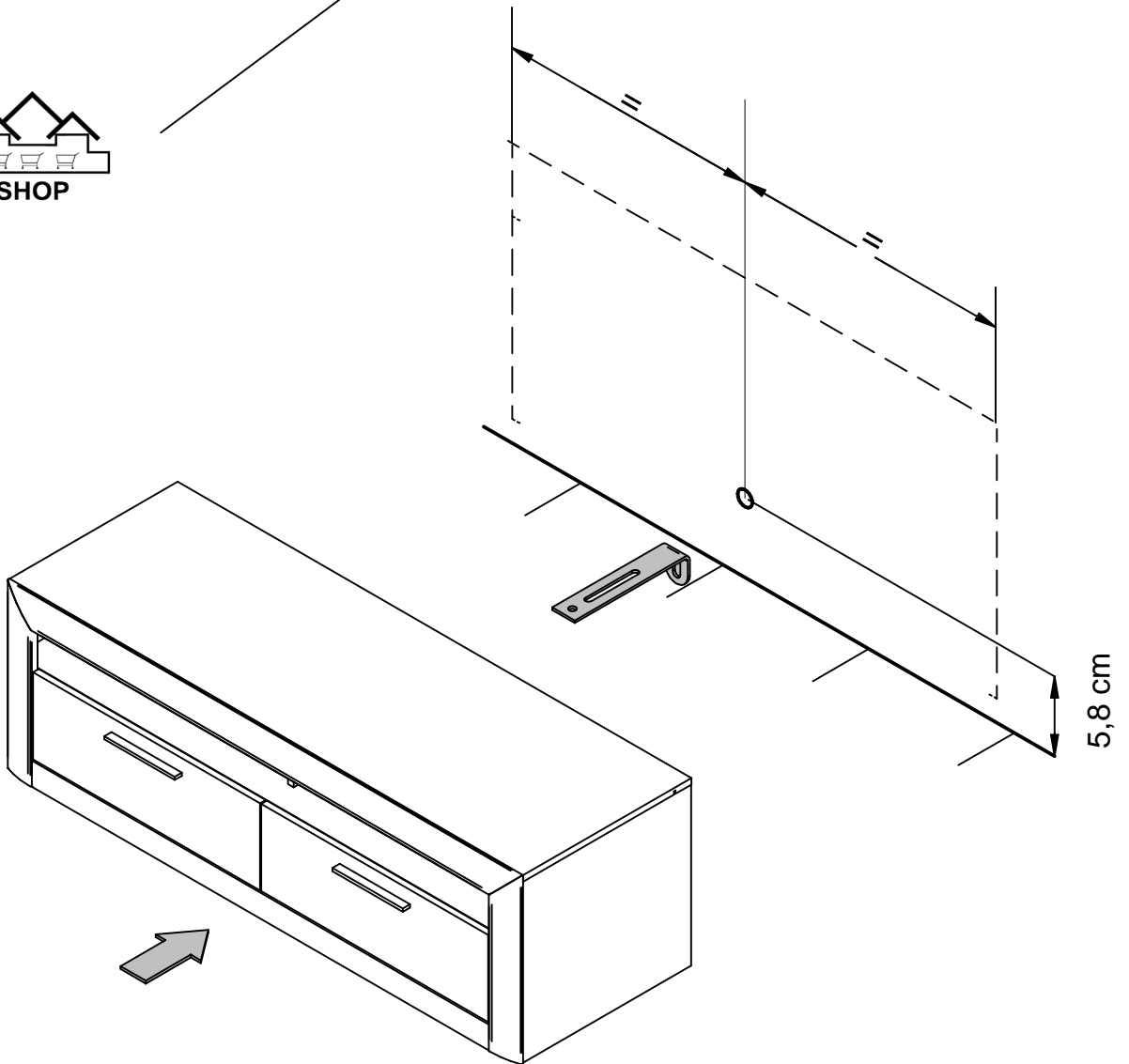
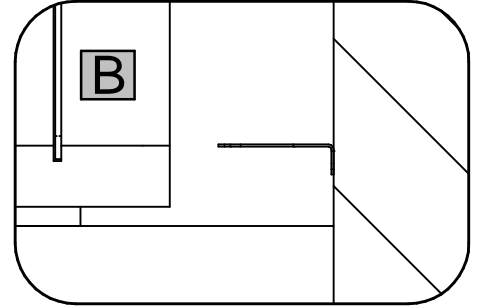
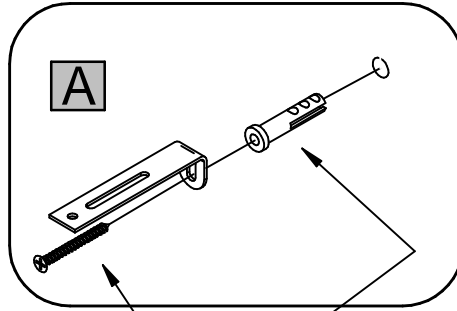
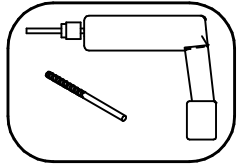
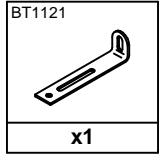

21.

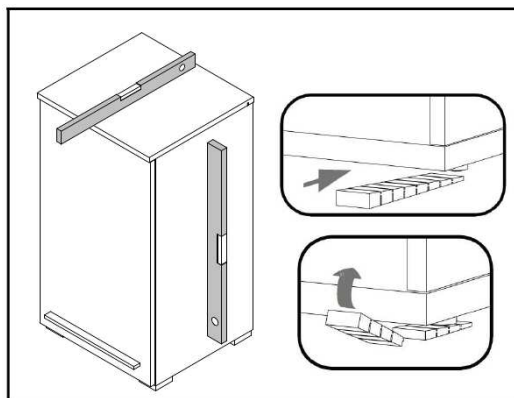
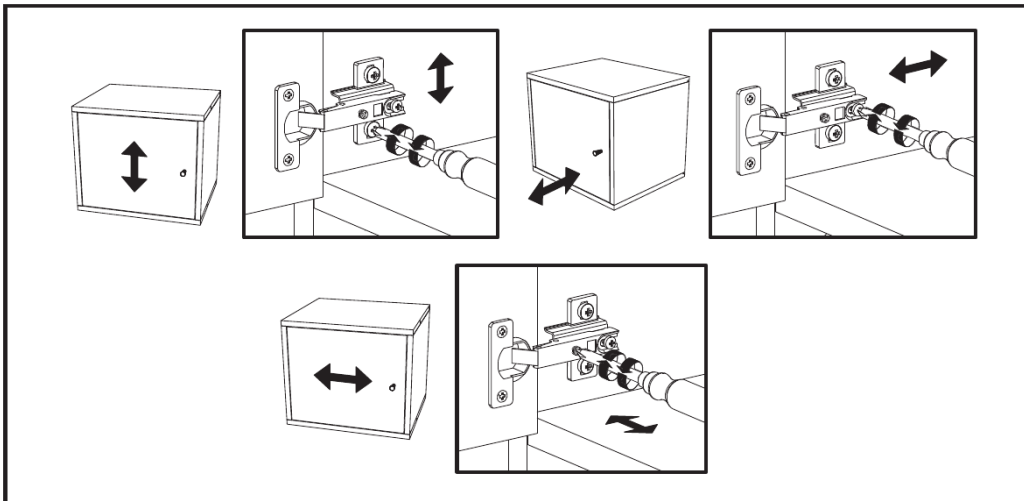
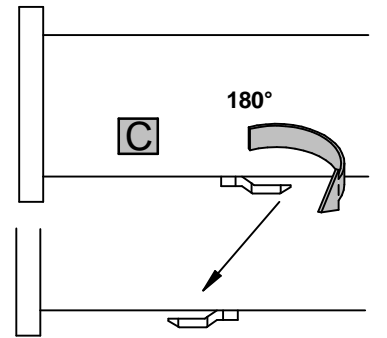
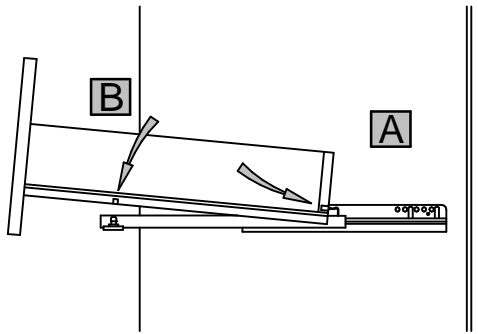
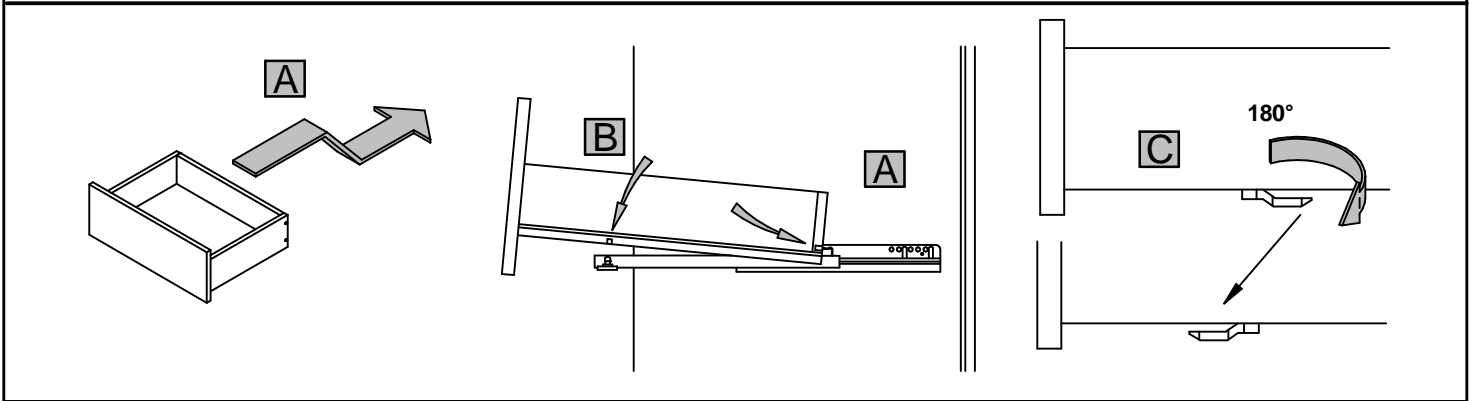
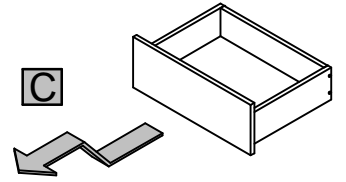
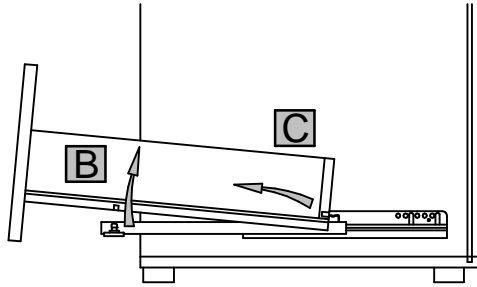
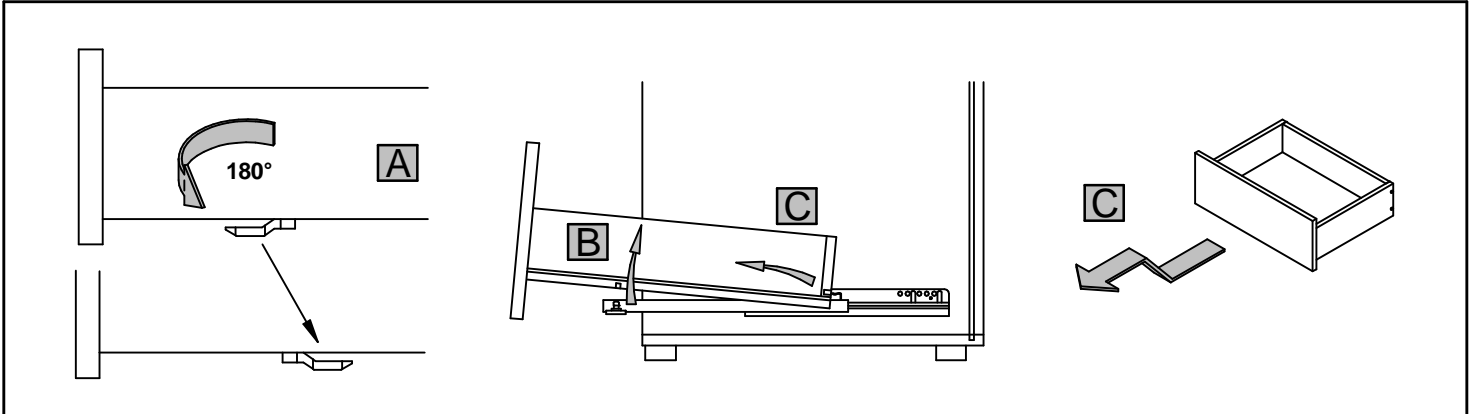
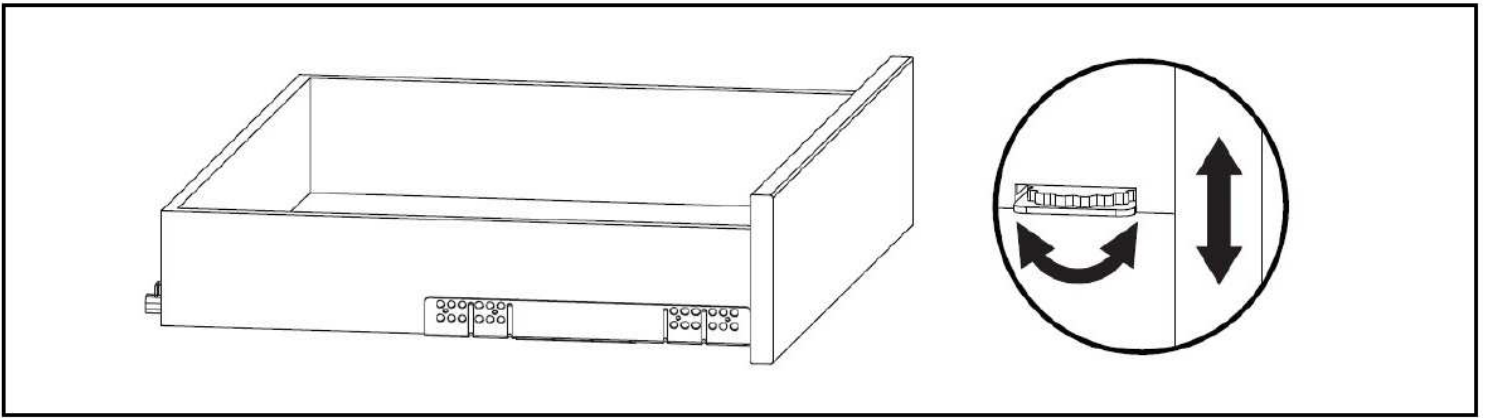



Modellname / Model name / Nom du modèle /
 Nome modello / Název modelu / Modelnaam / Ime modela
 Numéro Modello / Modell neve / Nombre del modelo /
 Názov modelu / Ime modela / Denumire model /
 Nome do modelo

Sarina

Modellnummer / Number / Numéro du modèle
 Numero / modello /
 Číslo modelu / Modell száma / Eíslo modelu
 Stevilka modela / Număr model

3047AW Artisan / Weiss

Type / Tipo / Tipus / Typ / Tip

20

Service für Beschlagteile

D Sollte Ihnen ein Beschlagteil fehlen, wenden Sie sich bitte mit dieser Servicekarte direkt an ihr Möbelhaus.

Service for fittings.

GB If you are missing a fitting part, please contact your furniture store directly with this service card.

Servis armatur.

CZ Pokud vám chybí montážní díl, obraťte se přímo na prodejce nábytku pomocí této servisní karty.

Service de montage.

F Si vous manquez une pièce appropriée, contactez directement votre magasin de meuble avec cette carte de service.

Servizio per raccordi.

I Se manca una parte di montaggio, contatta direttamente il tuo negozio di mobili con questa scheda di servizio.

Servicio de accesorios.

ES Si le falta una pieza de montaje, por favor contacte a su tienda de muebles directamente con esta tarjeta de servicio.

Service voor fittingen.

NL Als u een passend onderdeel mist, neem dan contact op met uw meubelwinkel met deze servicekaart.

Servis czesci montazowych.

PL Jeżeli brakuje części koniecznych do montażu, prosimy o kontakt ze sklepem meblarskim bezpośrednio z tą kartą serwisową.

Servis za armature.

HR Ako vam nedostaje dio za ugradnju, obratite se svojoj trgovini namještajem izravno s ovom servisnom karticom.

Szerviz szerelvényekhez.

HU Ha hiányzik egy illeszkedő rész, kérjük, forduljon bútor üzlethez közvetlenül ezzel a szervizzel.

Servis pre armatúry.

SK Ak vám chýba montážna časť, obráťte sa priamo na tento obchod s nábytkom prostredníctvom tejto servisnej karty.

Servis za opremo.

SLO Če manjkajte ustrezen del, se obrnite na prodajalno pohištva neposredno s to servisno kartico.









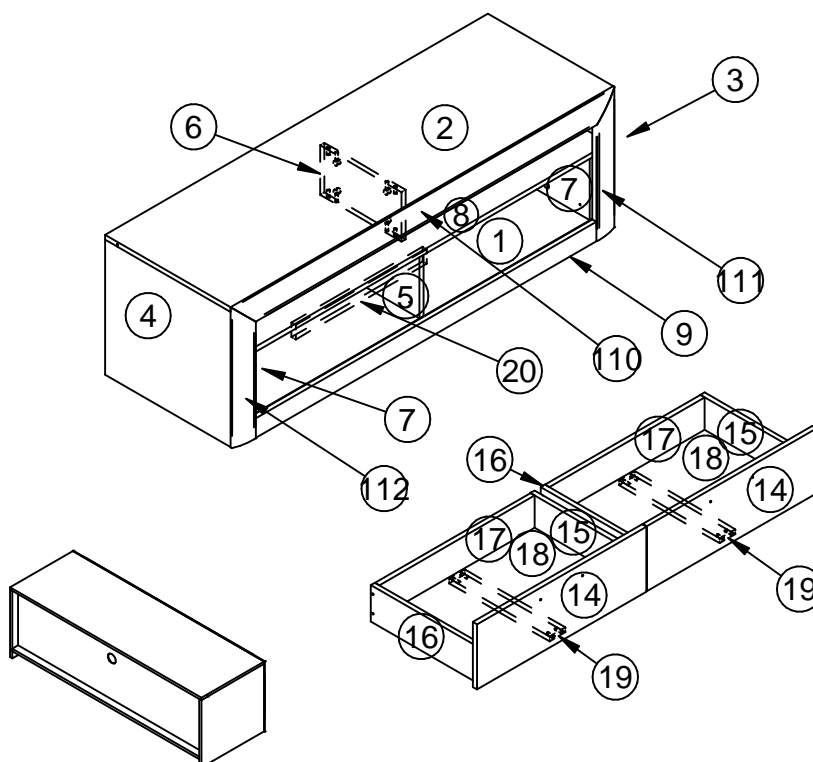











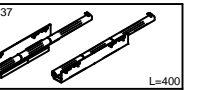

Service pentru armaturi.

RO Dacă vă lipsesc o piesă de montaj, vă rugăm să contactați magazinul de mobilier direct cu acest card de service.

Serviço de montagem.

PT Se você está faltando uma peça apropriada, entre em contato com sua loja de móveis diretamente com este cartão de serviço.



 x20	 x24 Silberbraun	 x46 Ø8x30	 x4	 x9 Ø2,7x20	 x10 Ø20	 x4 Ø7x1,5	 x1	 x6
 x18	 x36 Ø4x15	 x2 L=200 BA=128/160	 x4 Ø4x27	 x6 Ø7,7x45	 x1 4mm	 x2 L=400		
 x8 Ø6,3x8	 x8 Ø4x40	 x4	 x4 mit Rand	 x1 Ø60	 x8 Ø3,5x13	 x4		

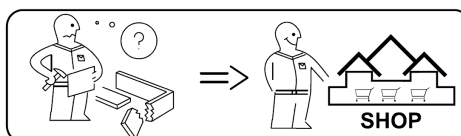

12.03.2020