

# 6741

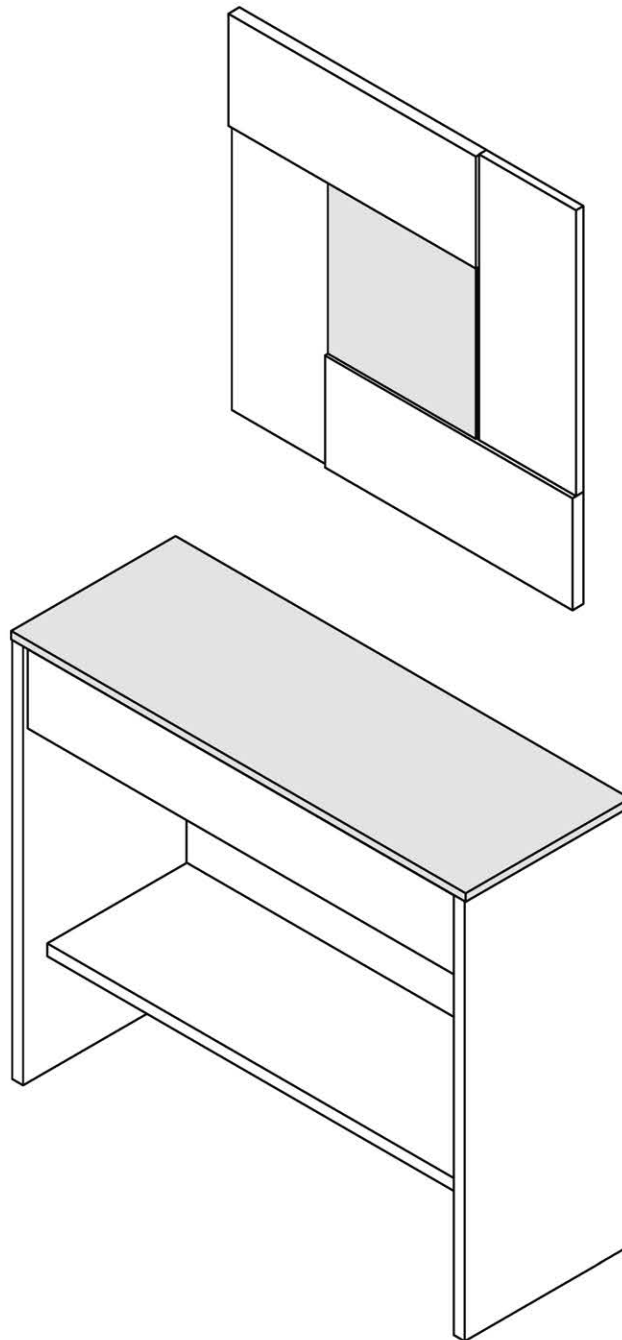

---

**RECIBIDOR - HALL FURNITURE - MEUBLE D'ENTRÉE -  
CONJUNTO HALL - MOBILI INGRESSO -  
FLURMÖBEL - ΈΠΙΠΛΑ ΕΙΣΟΔΟΥ**

INSTRUCCIONES DE MONTAJE - ASSEMBLING INSTRUCTIONS - NOTICE DE MONTAGE - INSTRUÇÕES DE MONTAGEM -  
ISTRUZIONI DI MONTAGGIO - MONTAGEANLEITUNG - ΟΔΗΓΙΕΣ ΣΥΝΑΡΜΟΛΟΓΗΣΗΣ

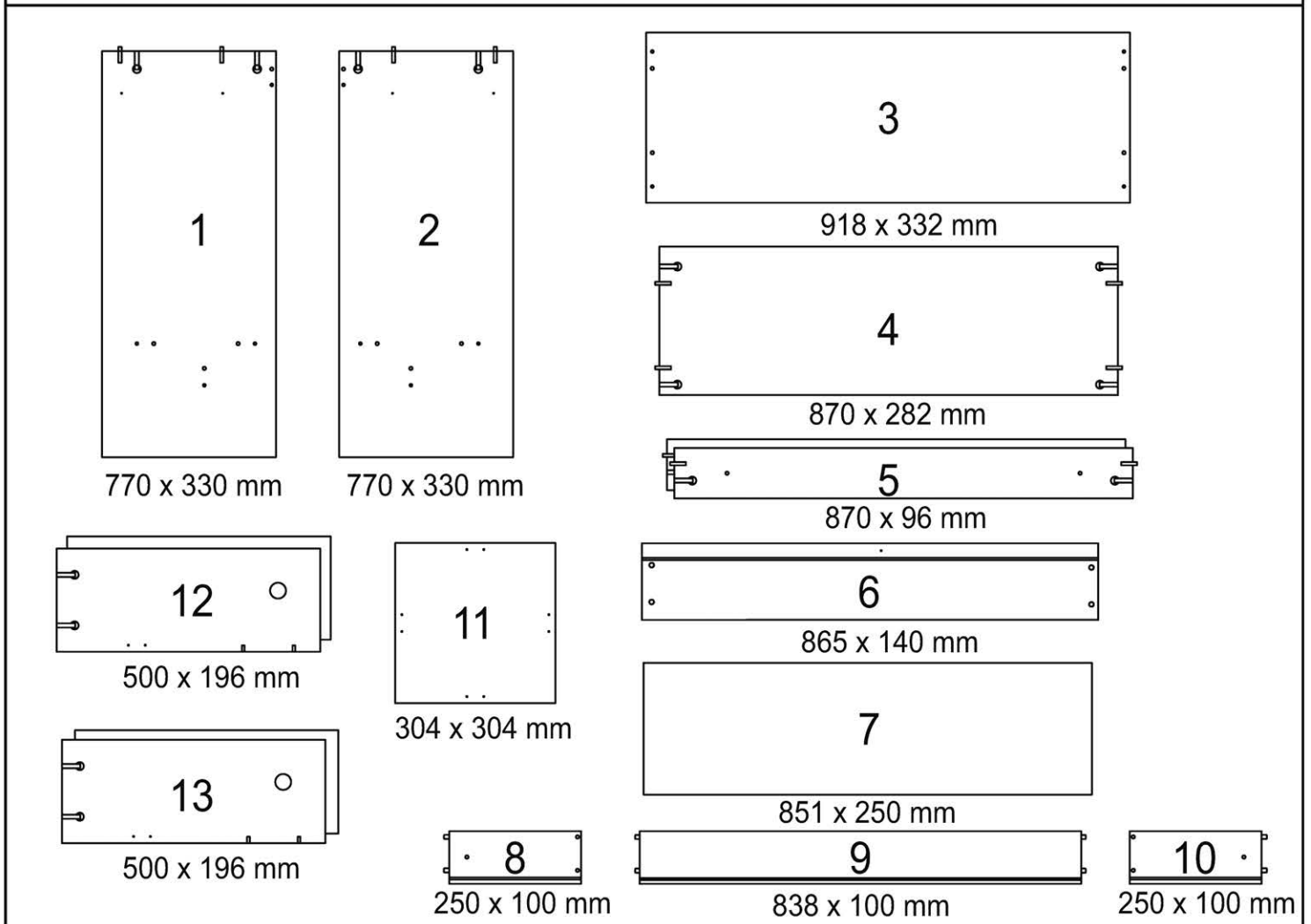
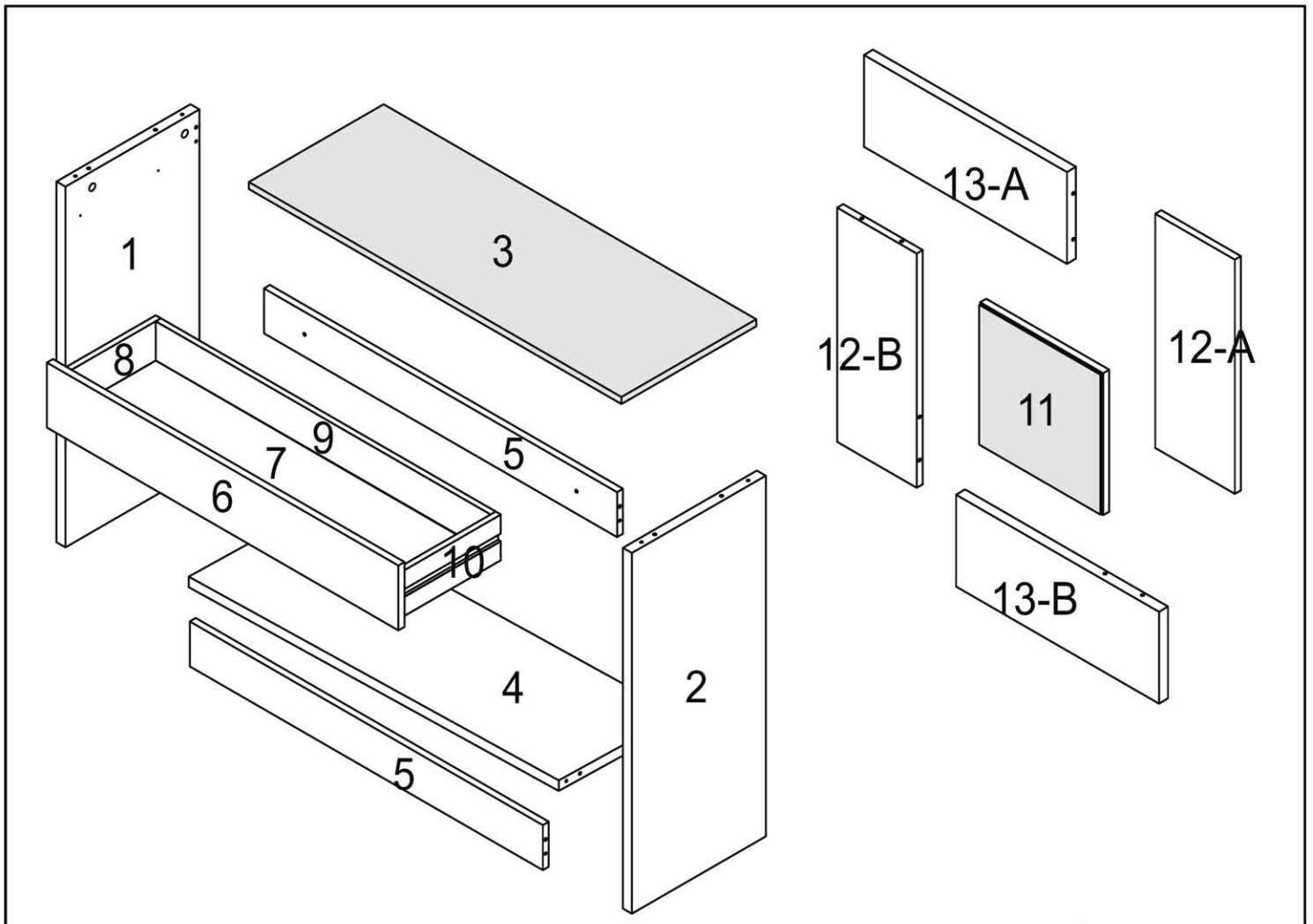

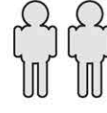
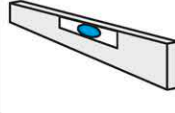
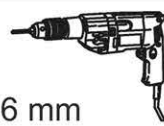
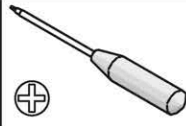
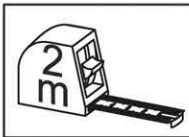

2 h.

A x 12

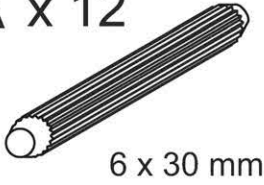

6 x 30 mm

C x 4



E x 20



F x 20

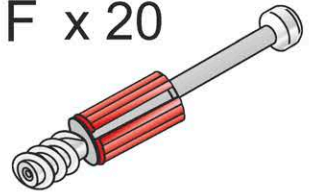

H x 2

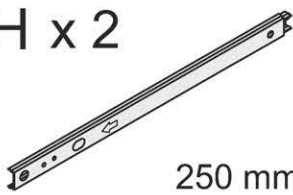

250 mm

L x 1



N x 4

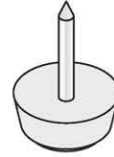

O x 1

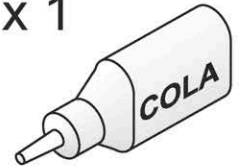

P x 2



Q x 2



W x 4

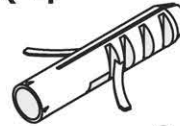



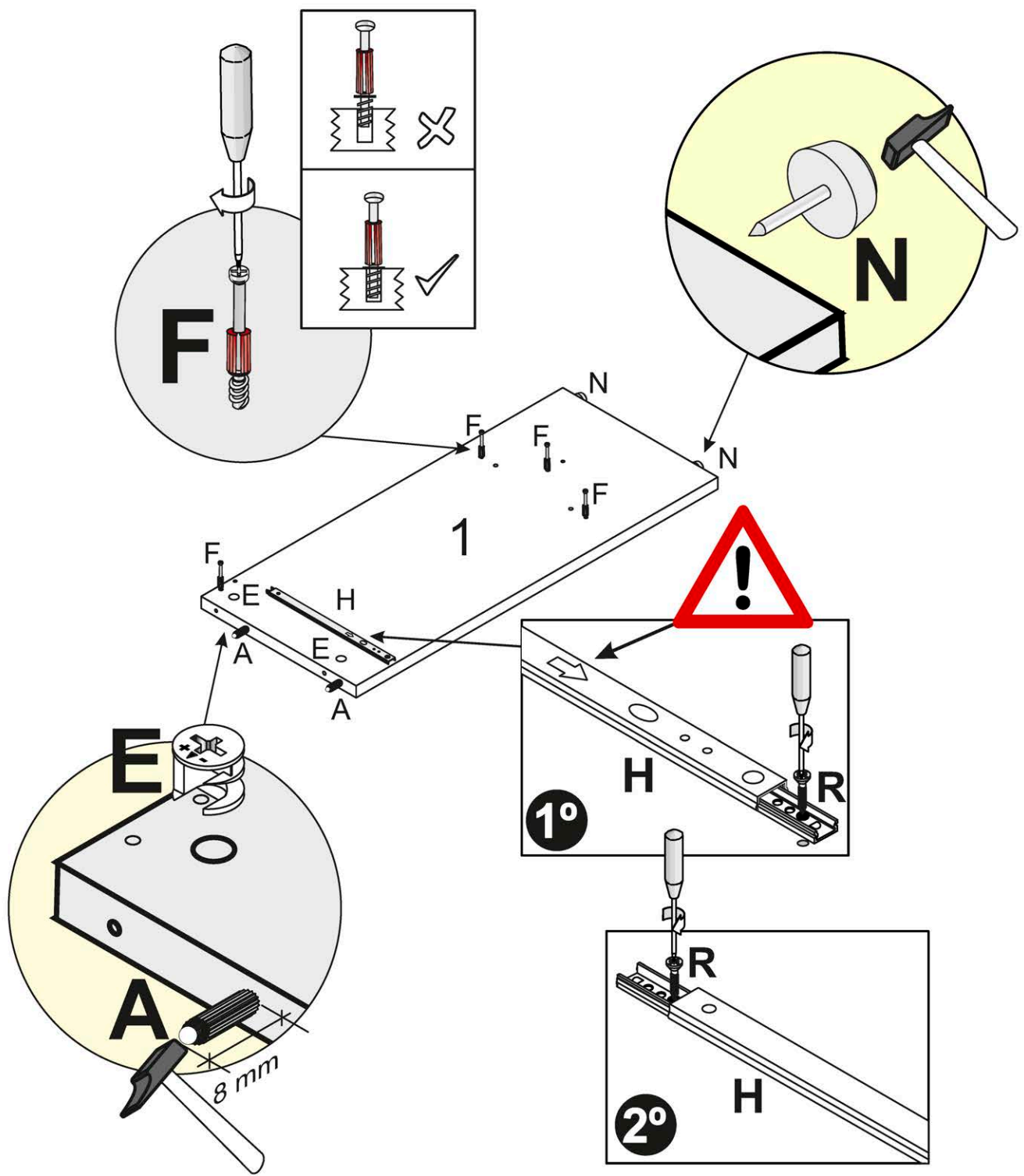

6 mm

		0	1 cm.	2	3	4	5
		<b>R x 4</b>		3 x 15 mm			
		<b>S x 17</b>		3.5 x 16 mm			
		<b>T x 2</b>		4,5 x 45 mm			
		<b>U x 2</b>		M4 x 8 mm			

1

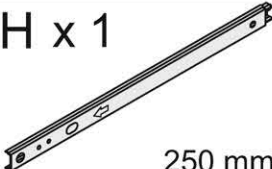
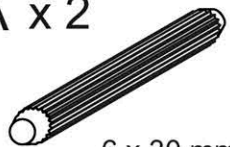

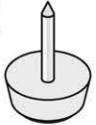
<p>R x 2</p>  <p>3 x 15 mm</p>		<p><del>S x 2</del></p>  <p><del>3,5 x 16 mm</del></p>		
<p>H x 1</p>  <p>250 mm</p>	<p>A x 2</p>  <p>6 x 30 mm</p>	<p>E x 2</p> 	<p>F x 4</p> 	<p>N x 2</p> 

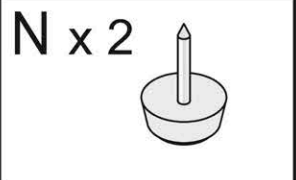
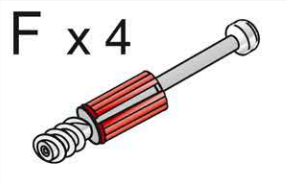
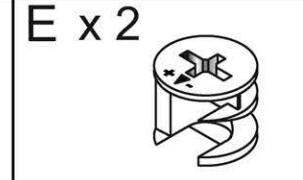
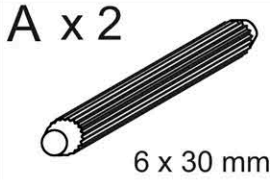
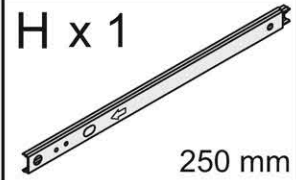
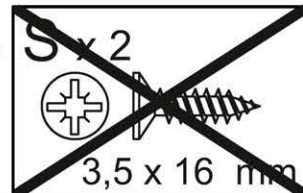
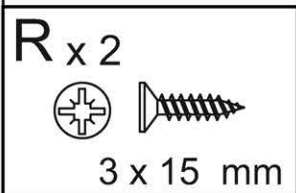
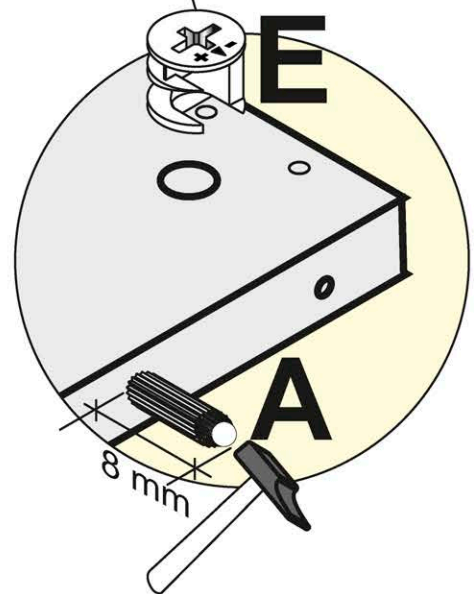
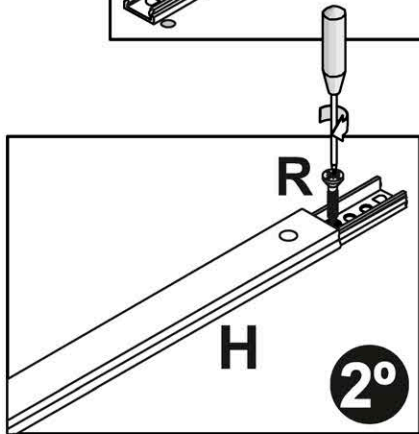
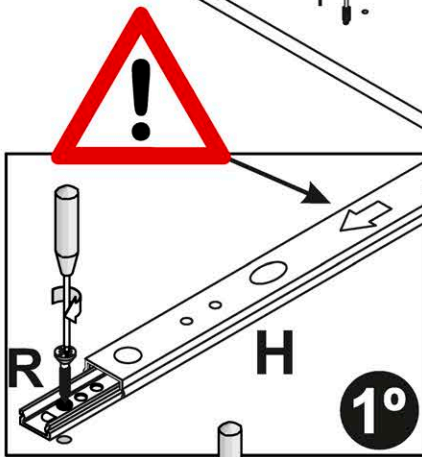
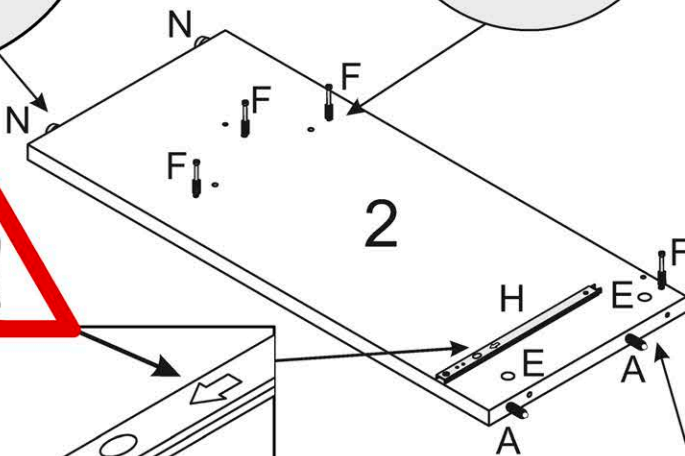
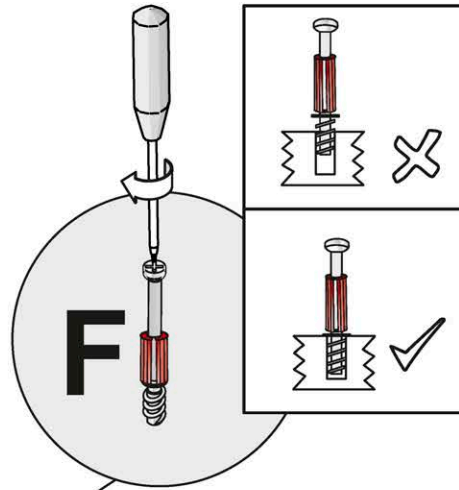
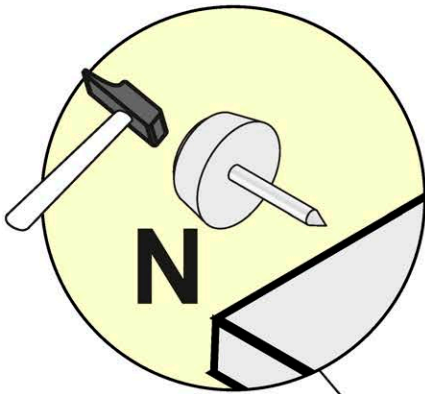



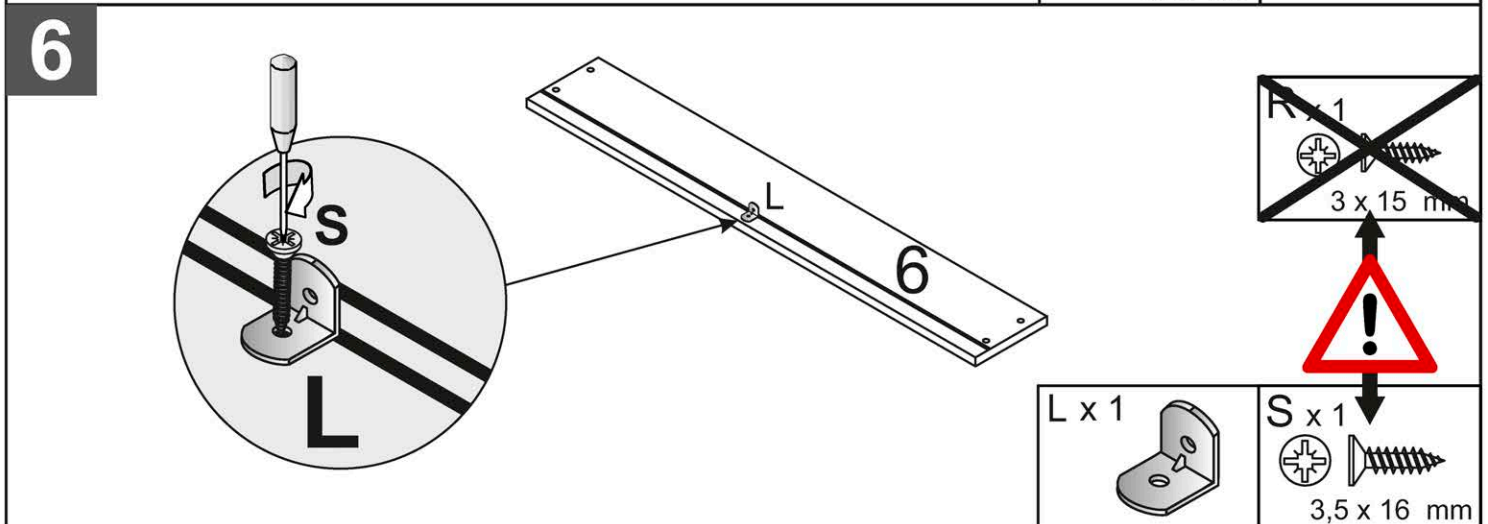
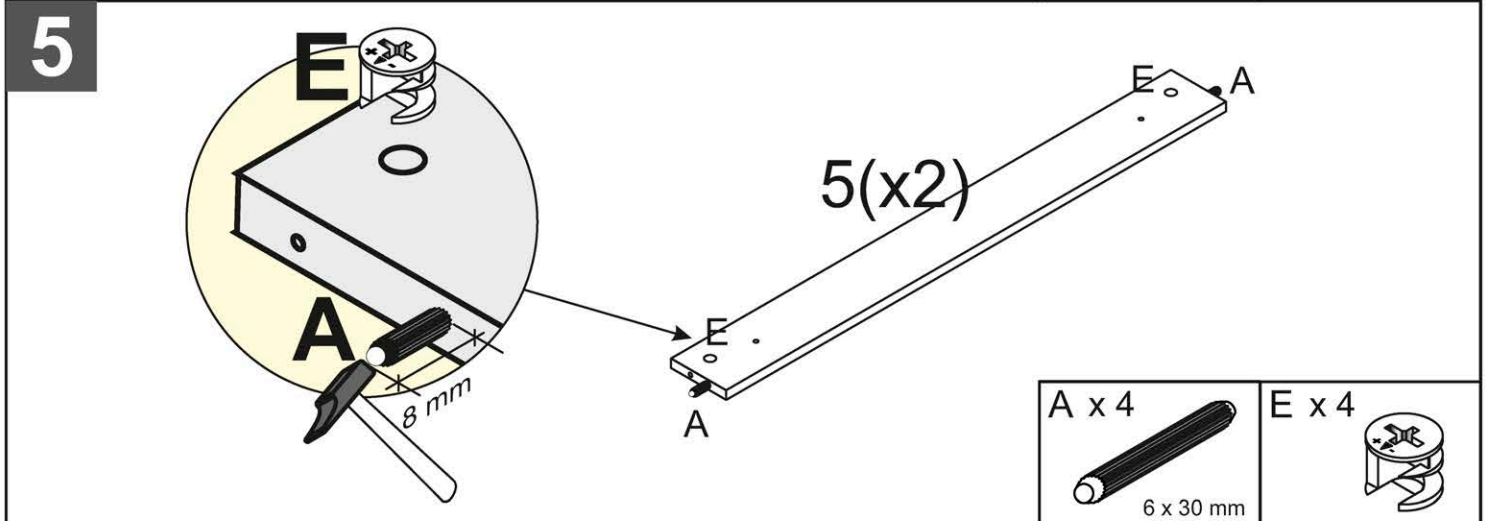
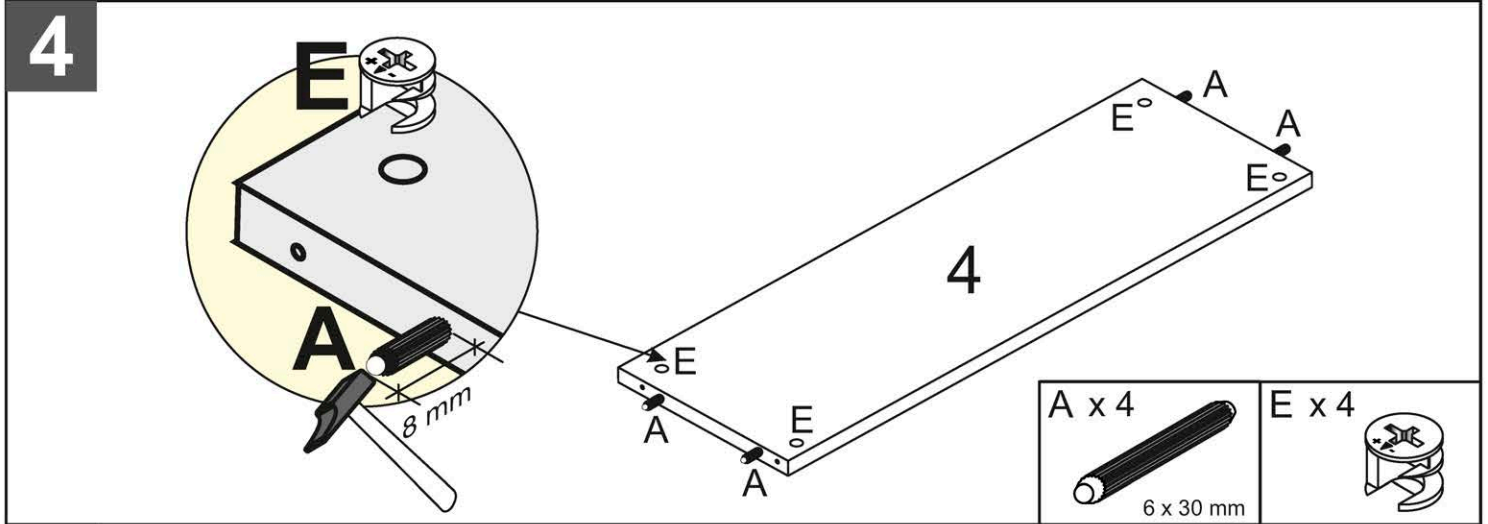
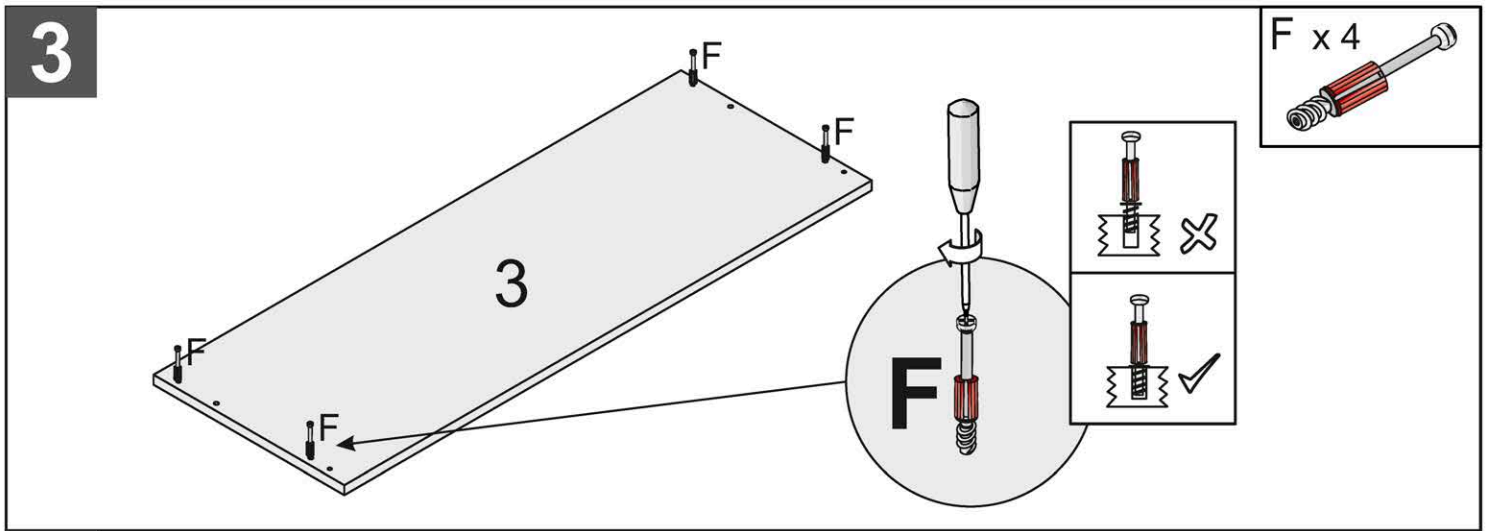

7

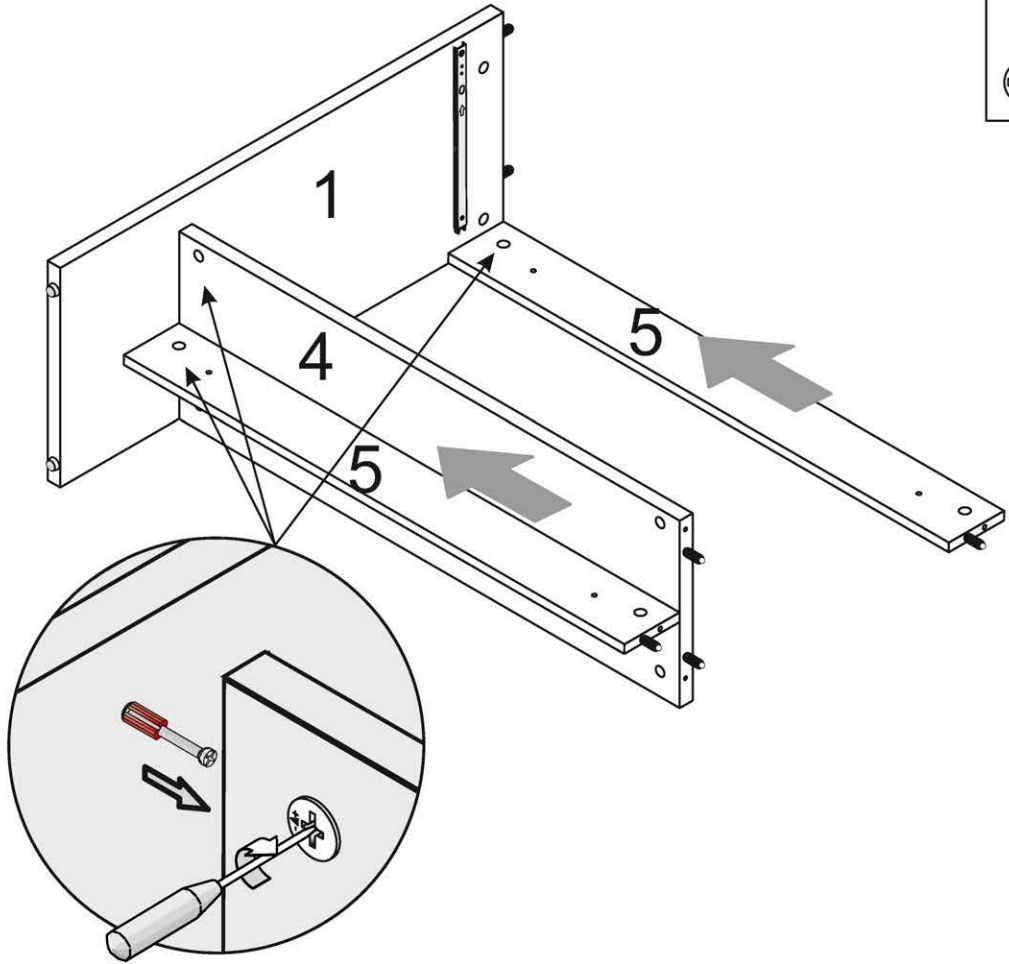
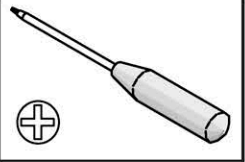

8

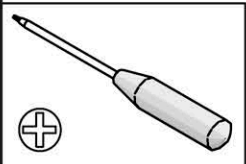
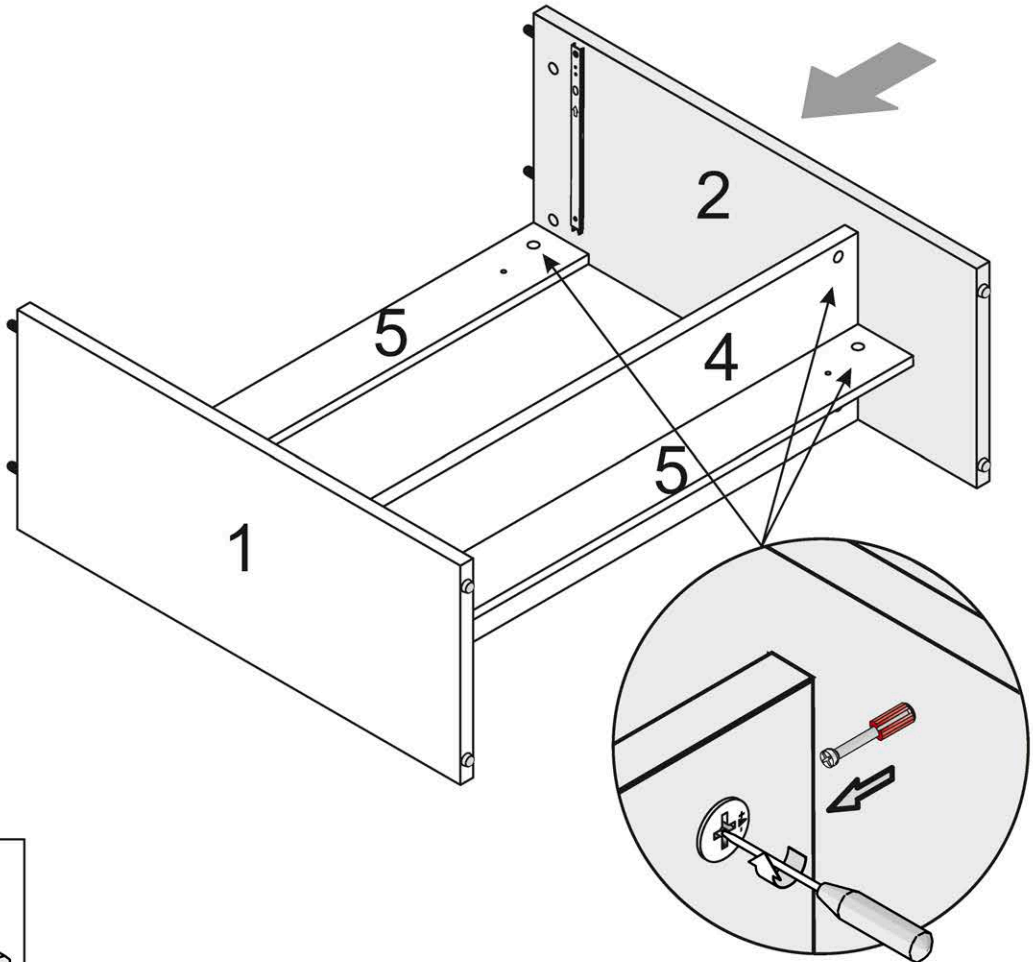

9

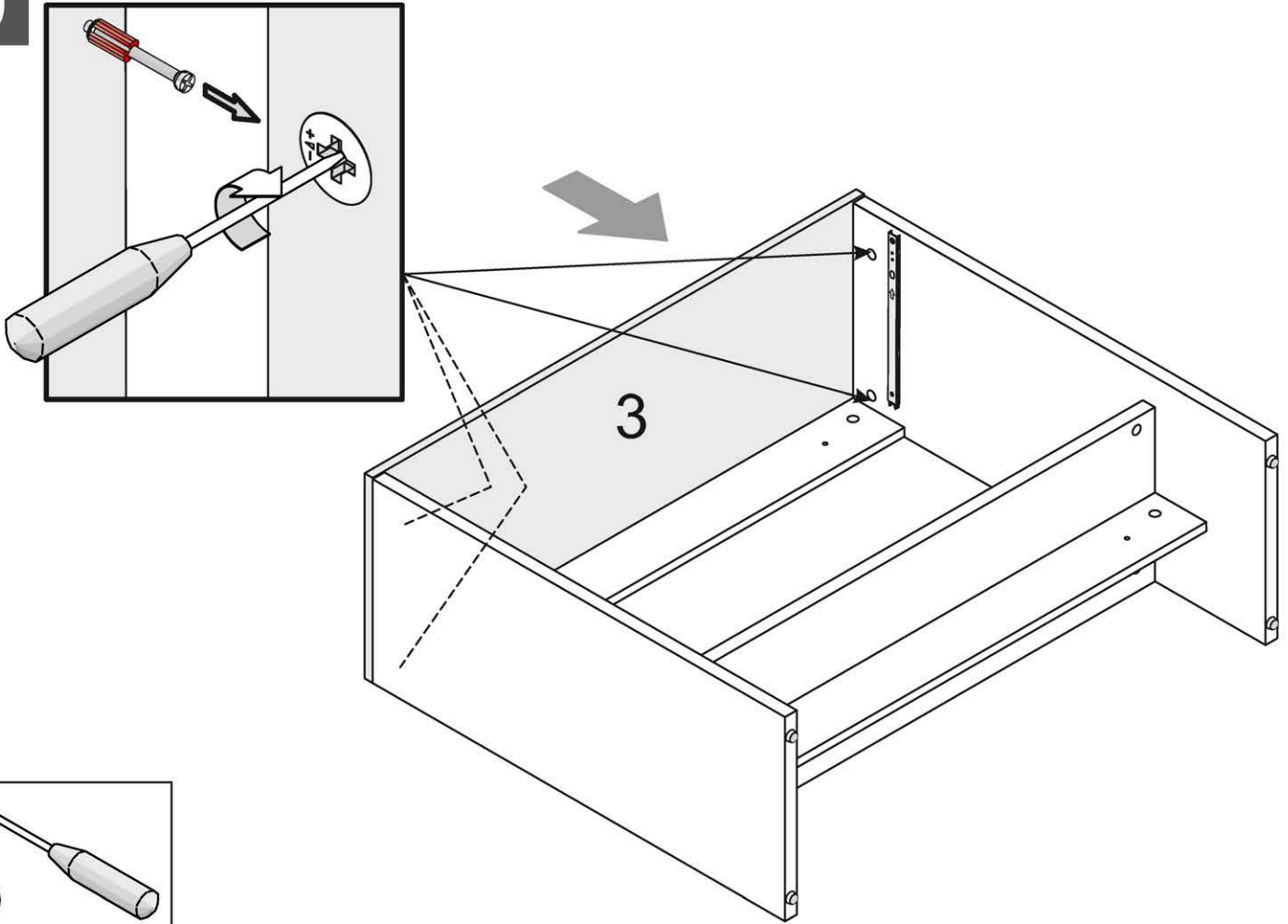

10

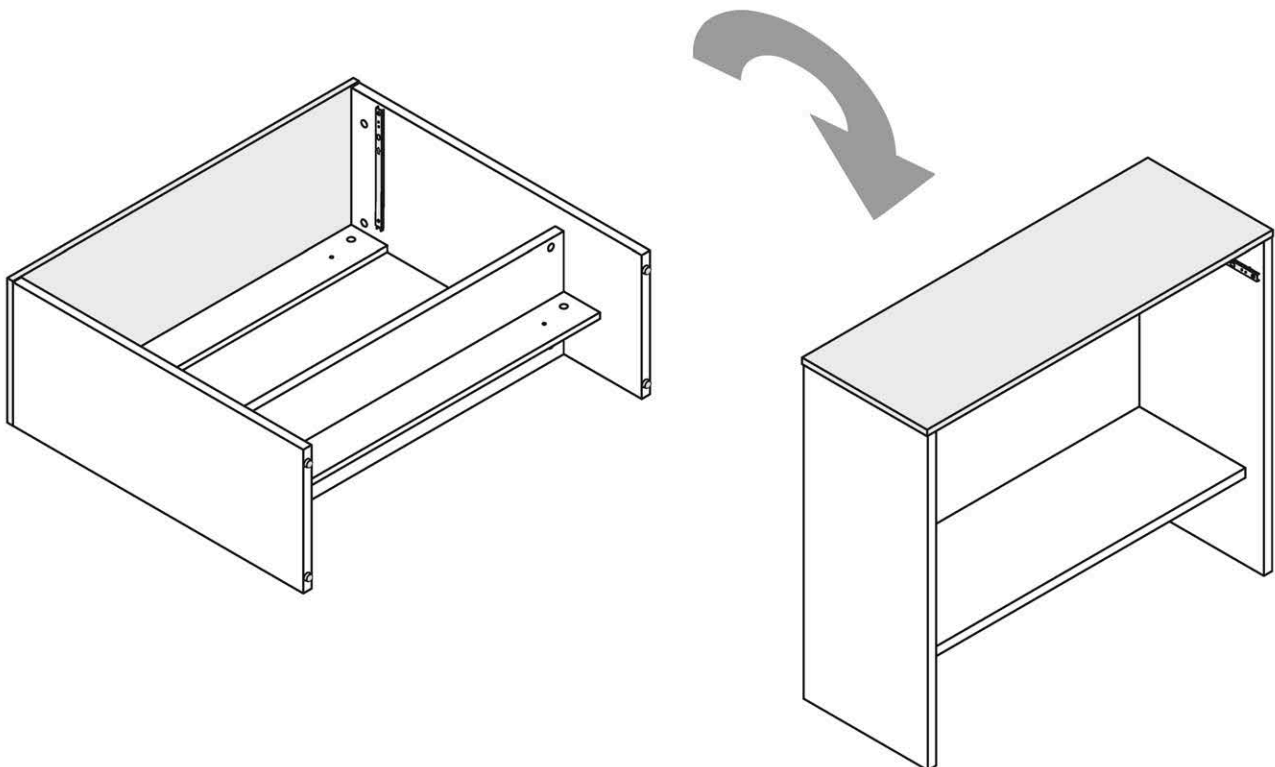
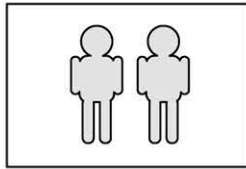





**ES** · USE HERRAJES ADECUADOS PARA EL MATERIAL DE LAS PAREDES DE SU CASA. LOS TACOS DE PARED INCLUIDOS SON PARA PAREDES DE HORMIGÓN O DE LADRILLO. PARA OTROS TIPOS DE PARED, COMO LAS DE PLADUR, PIDA CONSEJO A UN ESPECIALISTA.

**EN** · USE FIXING DEVICES SUITABLE FOR THE WALLS IN YOUR HOME. THE WALL PLUG INCLUDED ARE SUITABLE FOR CONCRETE OR BRICK WALLS. FOR OTHER TYPES OF WALLS, SUCH AS PLASTER, WE RECOMMEND CONTACTING A SPECIALIST.

**FR** · UTILISEZ DES FIXATIONS ADAPTÉES AU MUR DE VOTRE MAISON. LES CHEVILLES DE FIXATION INCLUSES S'ACCROCHENT AUX PAROIS EN BÉTON OU EN BRIQUE. POUR D'AUTRES TYPES DE MURS, COMME GYPROC OU PLÂTRE, VEUILLEZ CONTACTER UN SPÉCIALISTE.

**PT** · USE AS FERRAGENS ADEQUADAS AO MATERIAL DAS PAREDES DE SUA CASA. AS BUCHAS INCLUIDAS SÃO PARA PAREDES DE CIMENTO OU TIJOLO. PARA OUTROS TIPOS DE PAREDE, TAIS COMO PLACAS DE GESSO, CONSULTE UM ESPECIALISTA.

**IT** · USA SISTEMI DI FISSAGGIO ADATTI ALLE PARETI DELLA TUA CASA. I TASSELLI A MURO INCLUSI SONO ADATTI PER PARETE IN CEMENTO O MATTONI. PER FISSAGGIO IN ALTRI TIPI DI MATERIALE, COME PARETE IN CARTONGESSO, CHIEDERE CONSIGLIO AD UN PROFESSIONISTA.

**DE** · BEFESTIGUNGSBESCHLÄGE BENUTZEN, DIE FÜR DIE HEIMISCHEN WÄNDE GEEIGNET SIND. DIE DÜBEL VON WÄNDE INKLUSIVE SIND A FÜR WÄNDE VON BETON ODER ZIEGELWÄNDEN. FÜR ANDERE WIE GIPSKARTONPLATTEN BIETET DEN RAT EINES SPEZIALISTEN.

**GR** · ΧΡΗΣΙΜΟΠΟΙΗΣΤΕ ΕΞΑΡΤΗΜΑΤΑ ΣΤΕΡΕΩΣΗΣ ΚΑΤΑΛΛΗΛΑ ΓΙΑ ΤΟΥΣ ΤΟΙΧΟΥΣ ΤΟΥ ΣΠΙΤΙΟΥ ΣΑΣ. ΟΙ ΣΥΝΔΕΤΙΚΟ ΚΑΡΦΙ ΠΕΡΙΛΑΜΒΑΝΟΝΤΑΙ ΓΙΑ ΤΟΙΧΟΥΣ ΤΟΙΧΟΥΣ ΣΚΥΔΡΟΜΕΝΟΥ Ή ΤΟΙΧΟΥΣ ΑΠΟ ΤΟΥΒΛΑ. ΓΙΑ ΑΛΛΟΥΣ ΤΥΠΟΥΣ ΤΟΙΧΟΥΣ, Π.Χ ΓΥΦΟΣΑΝΙΔΑΣ, ΕΠΙΚΟΙΝΩΝΗΣΤΕ ΜΕ ΕΙΔΙΚΟ.

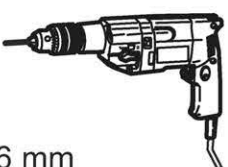
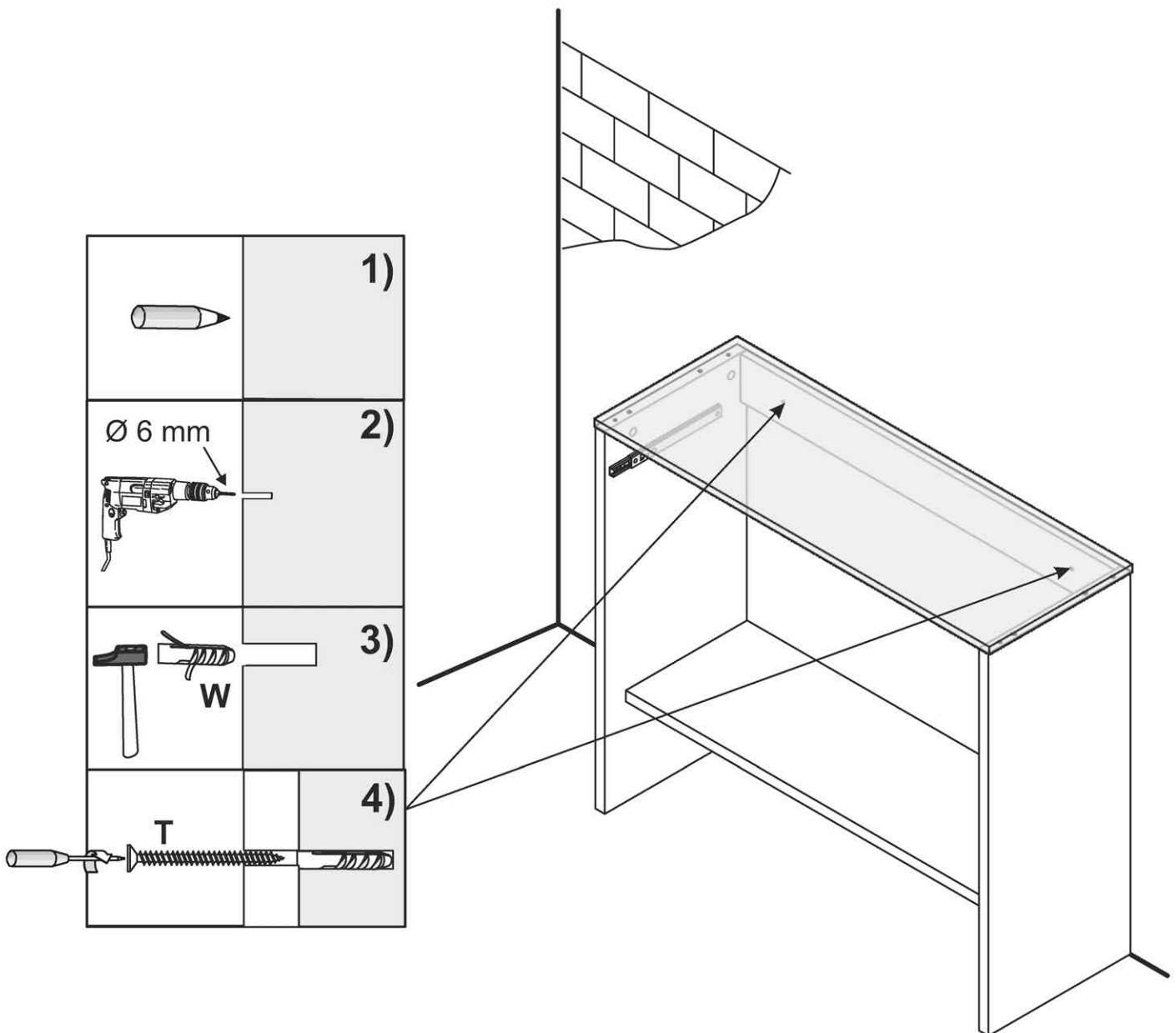

6 mm

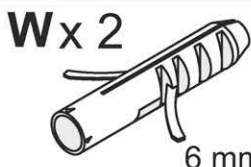

W x 2

6 mm



T x 2

4.5 x 45 mm

# 12

**E** **13(x2)** **F**

**12(x2)** **C** **S**

**F x 8**

**E x 8**

**C x 4** **S x 8** **3,5 x 16 mm**

**R x 8** **3 x 15 mm**

**!**

# 13

**13-A** **12-B**

**12-A** **13-B**

**!**

**+**

14

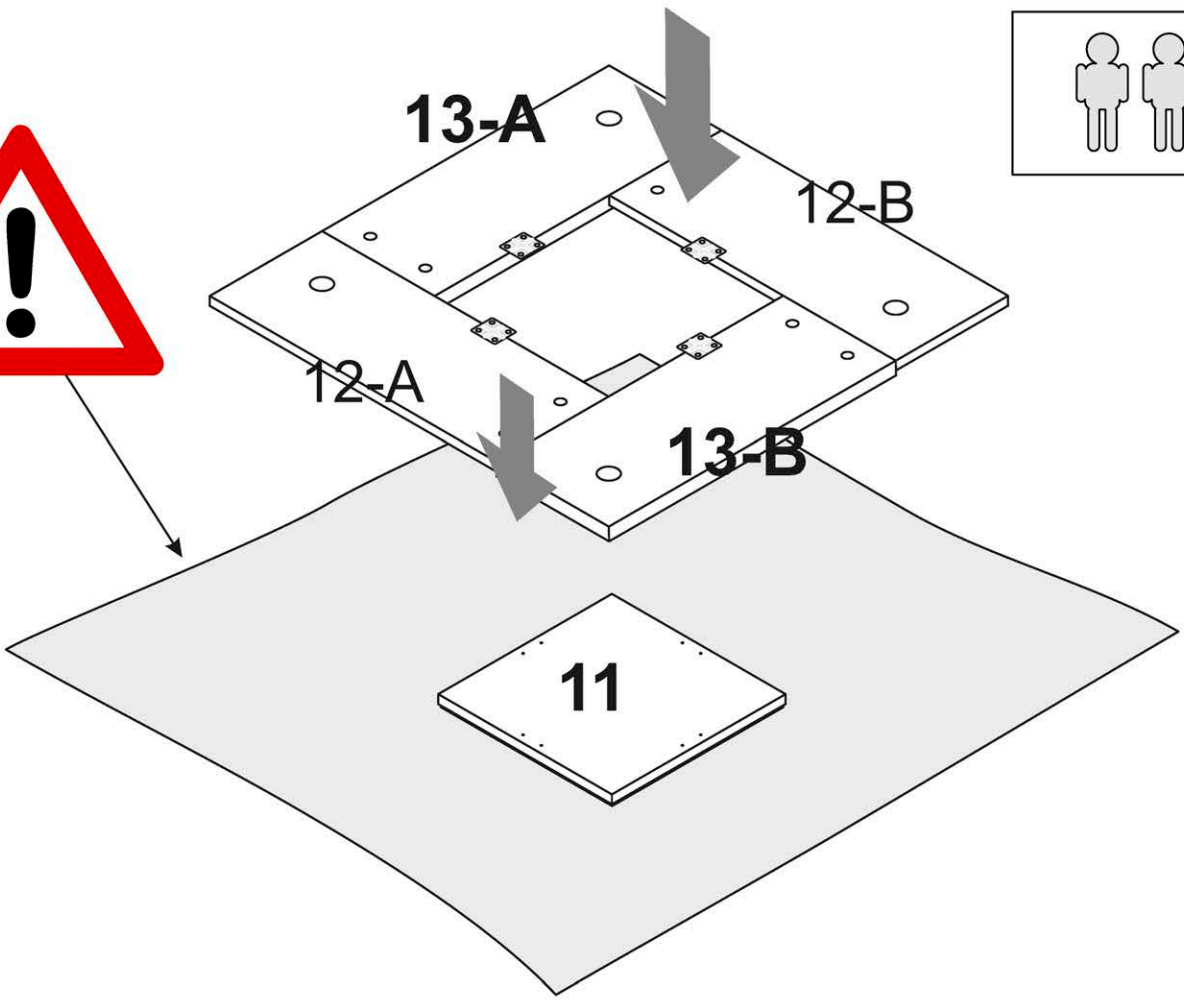
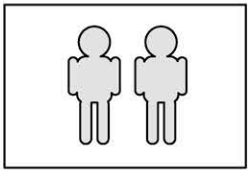

15

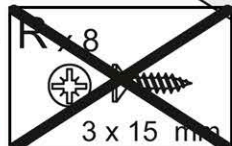
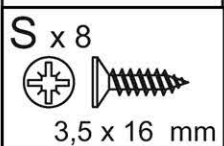
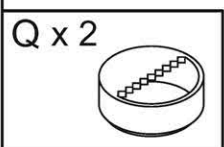
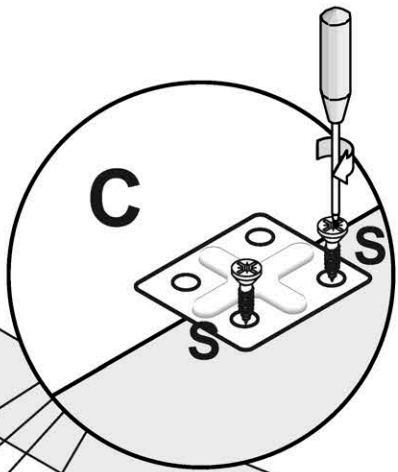
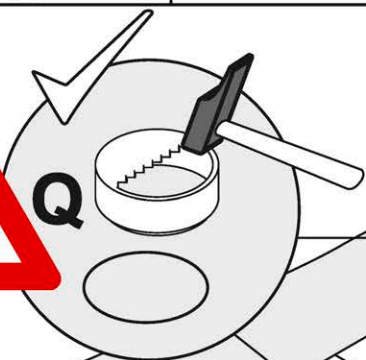
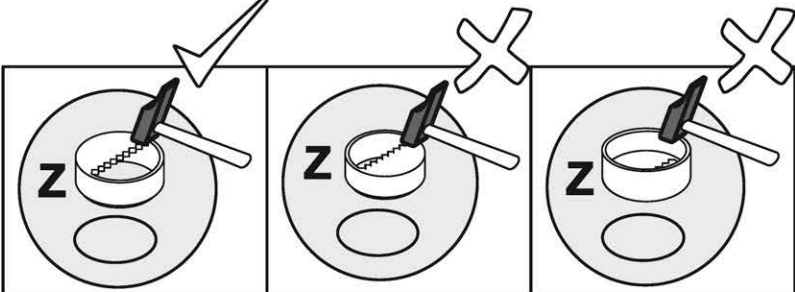



16

1°

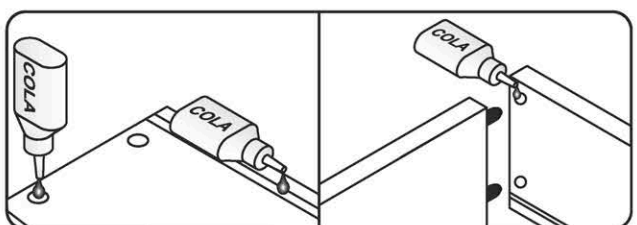
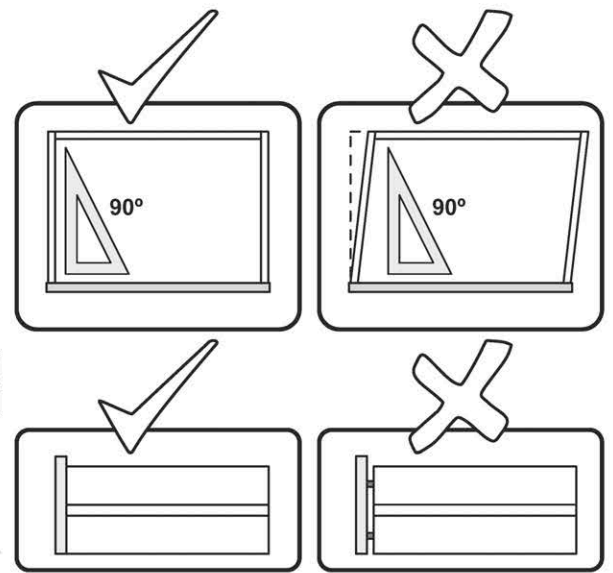
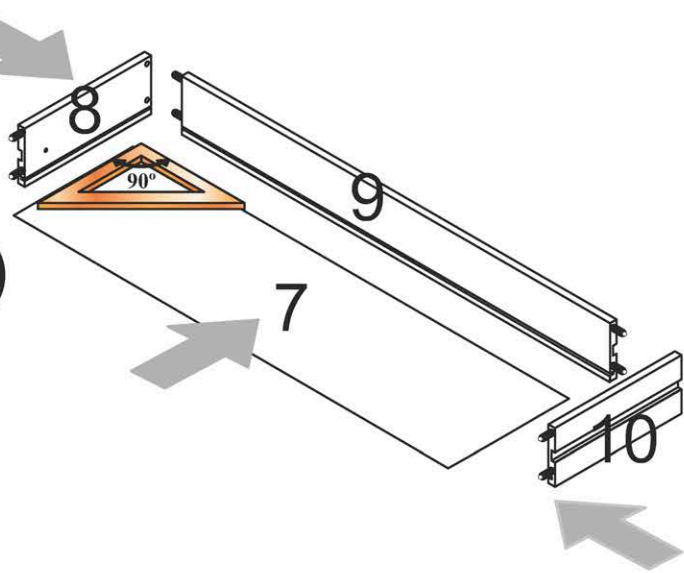

2°

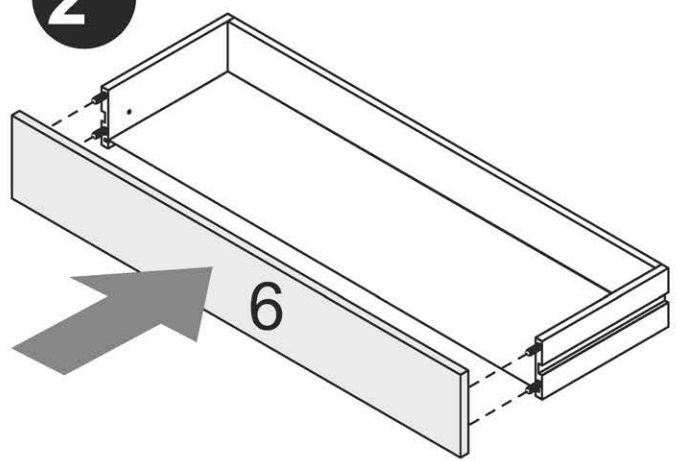

3°

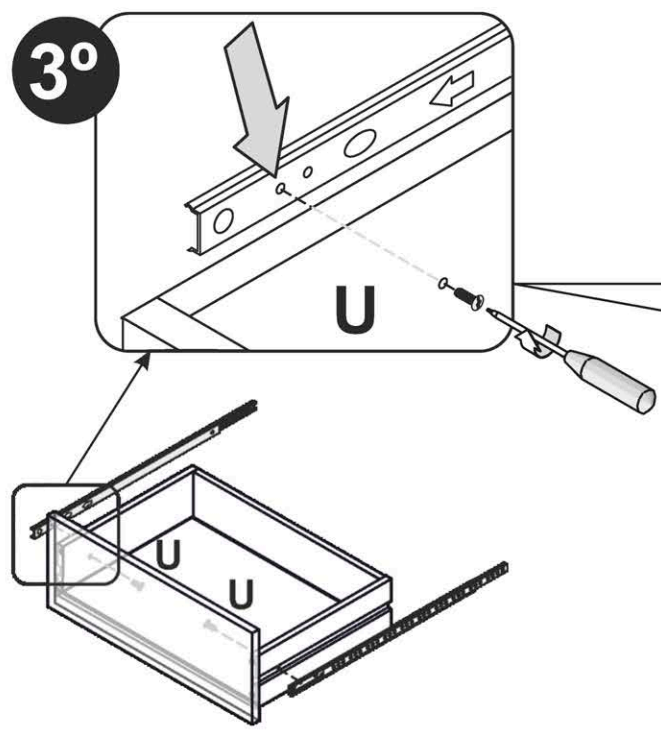

4°

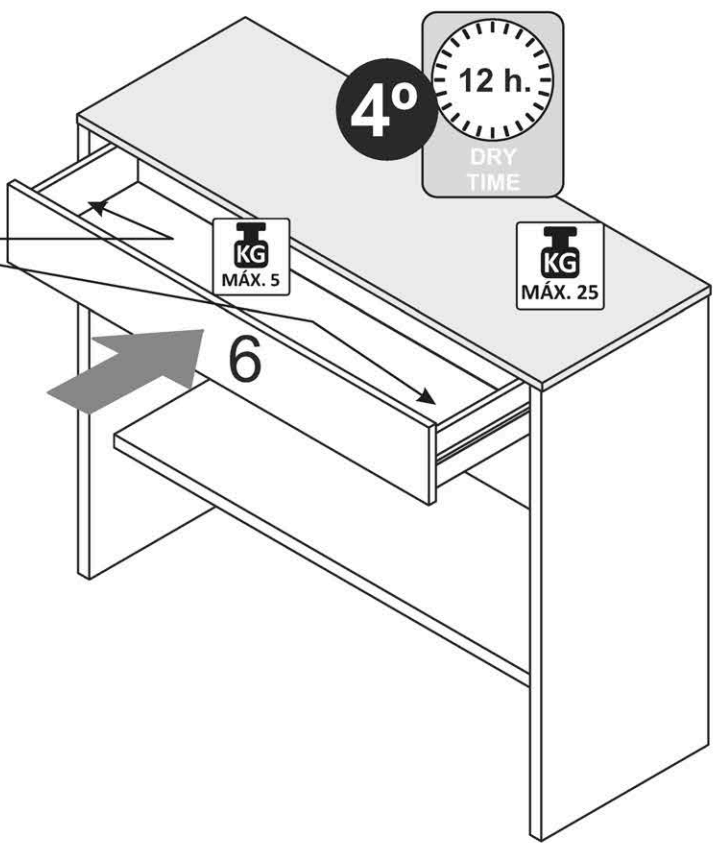

- O x 1 COLA COLLE GLUE
- U x 2 4 x 8 mm

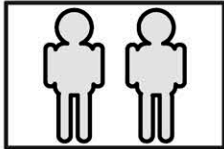

- ES** · USE HERRAJES ADECUADOS PARA EL MATERIAL DE LAS PAREDES DE SU CASA. LOS TACOS DE PARED INCLUIDOS SON PARA PAREDES DE HORMIGÓN O DE LADRILLO. PARA OTROS TIPOS DE PARED, COMO LAS DE PLADUR, PIDA CONSEJO A UN ESPECIALISTA.
- EN** · USE FIXING DEVICES SUITABLE FOR THE WALLS IN YOUR HOME. THE WALL PLUG INCLUDED ARE SUITABLE FOR CONCRETE OR BRICK WALLS. FOR OTHER TYPES OF WALLS, SUCH AS PLASTER, WE RECOMMEND CONTACTING A SPECIALIST.
- FR** · UTILISEZ DES FIXATIONS ADAPTÉES AU MUR DE VOTRE MAISON. LES CHEVILLES DE FIXATION INCLUSES S'ACCROCHENT AUX PAROIS EN BÉTON OU EN BRIQUE. POUR D'AUTRES TYPES DE MURS, COMME GYPROC OU PLÂTRE, VEUILLEZ CONTACTER UN SPÉCIALISTE.

- PT** · USE AS FERRAGENS ADEQUADAS AO MATERIAL DAS PAREDES DE SUA CASA. AS BUCHAS INCLUIDAS SÃO PARA PAREDES DE CIMENTO OU TIJOLO. PARA OUTROS TIPOS DE PAREDE, TAIS COMO PLACAS DE GESSO, CONSULTE UM ESPECIALISTA.
- IT** · USA SISTEMI DI FISSAGGIO ADATTI ALLE PARETI DELLA TUA CASA. I TASSELLI A MURO INCLUSI SONO ADATTI PER PARETE IN CEMENTO O MATTONI. PER FISSAGGIO IN ALTRI TIPI DI MATERIALE, COME PARETE IN CARTONGESSO, CHIEDERE CONSIGLIO AD UN PROFESSIONISTA.
- DE** · BEFESTIGUNGSBESCHLÄGE BENUTZEN, DIE FÜR DIE HEIMISCHEN WÄNDE GEEIGNET SIND. DIE DÜBEL VON WÄNDE INKLUSIVE SIND A FÜR WÄNDE VON BETON ODER ZIEGELWÄNDEN. FÜR ANDERE WIE GIPSKARTONPLATTEN BIETET DEN RAT EINES SPEZIALISTEN.
- GR** · ΧΡΗΣΙΜΟΠΟΙΗΣΤΕ ΕΞΑΡΤΗΜΑΤΑ ΣΤΕΡΕΩΣΗΣ ΚΑΤΑΛΛΗΛΑ ΓΙΑ ΤΟΥΣ ΤΟΙΧΟΥΣ ΤΟΥ ΣΠΙΤΙΟΥ ΣΑΣ. ΟΙ ΣΥΝΔΕΤΙΚΟ ΚΑΡΦΙ ΠΕΡΙΛΑΜΒΑΝΟΝΤΑΙ ΓΙΑ ΤΟΙΧΟΥΣ ΤΟΙΧΟΥΣ ΣΚΥΔΡΟΜΕΝΟΥ Ή ΤΟΙΧΟΥΣ ΑΠΟ ΤΟΥΒΛΑ. ΓΙΑ ΑΛΛΟΥΣ ΤΥΠΟΥΣ ΤΟΙΧΟΥΣ, Π.Χ. ΓΥΦΟΣΑΝΙΔΑΣ, ΕΠΙΚΟΙΝΩΝΗΣΤΕ ΜΕ ΕΙΔΙΚΟ.

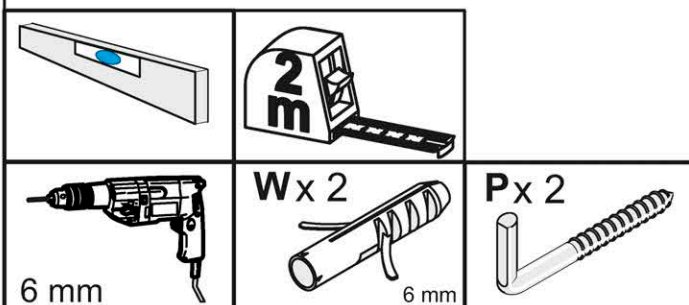
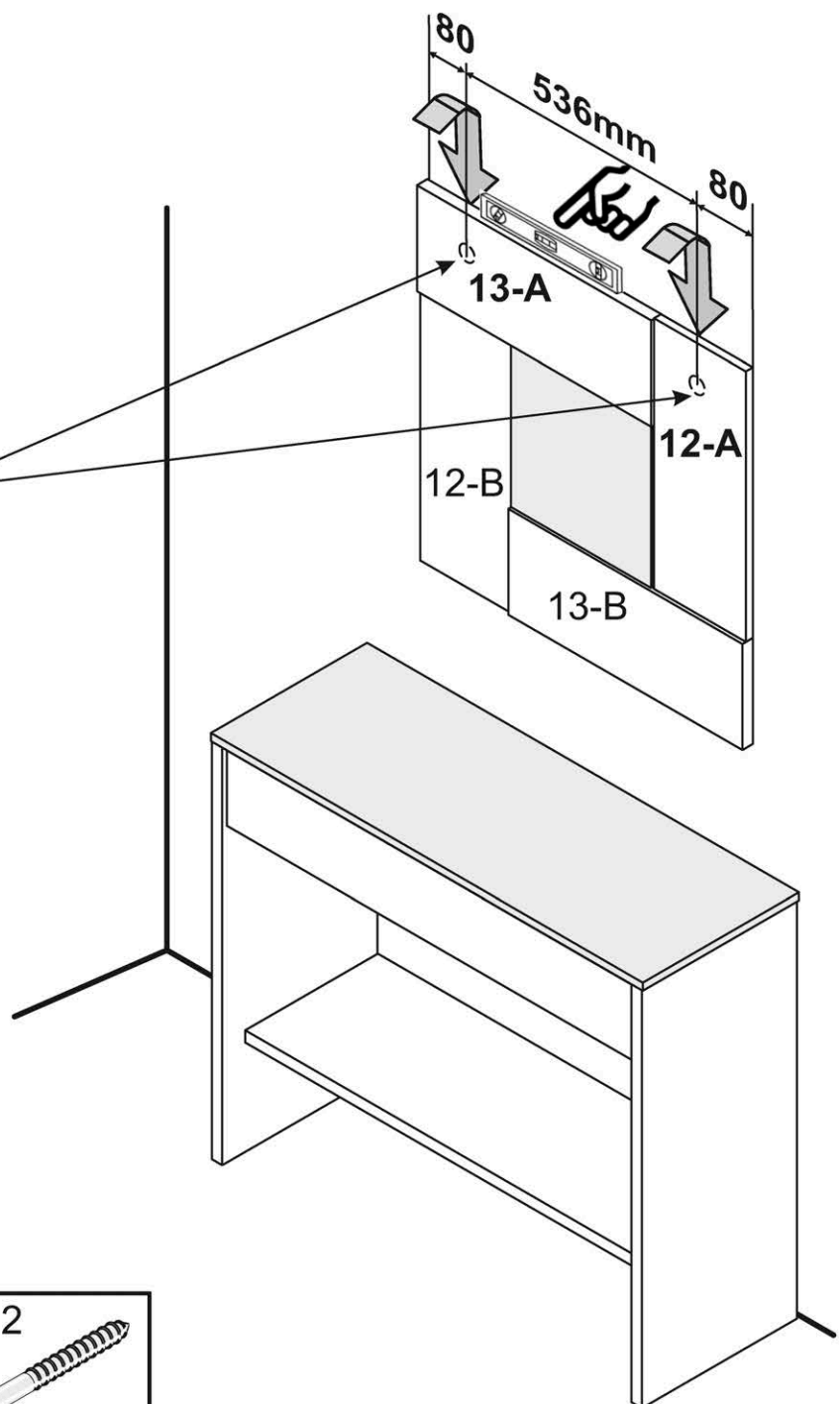
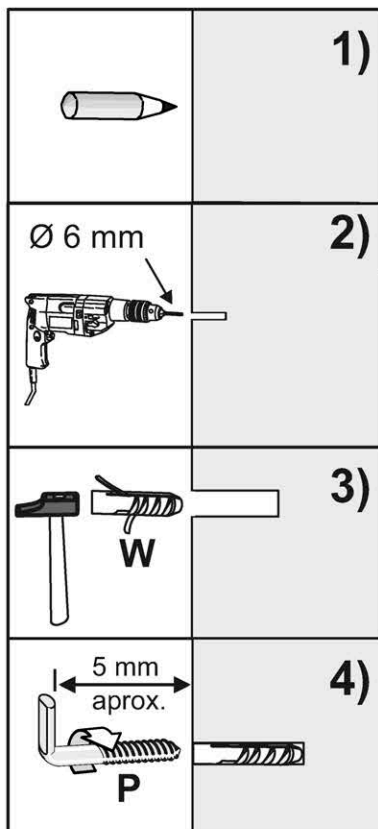



## ES

### INFORMACIÓN IMPORTANTE SOBRE EL MONTAJE DE LOS MUEBLES EN LA PARED

- Una vez montado según las instrucciones de montaje, el mueble está listo para montar en la pared. Un montaje de pared incorrecto puede ocasionar la caída del mueble y, por tanto, graves daños materiales y/o personales. El fabricante no se hace responsable de daños personales o materiales ocasionados por un montaje de pared incorrecto.
- La pared debe tener la resistencia necesaria para el montaje de los muebles en pared, no se debe realizar el montaje en paredes sin primero asegurarse de que la pared tenga la resistencia requerida o haya sido reforzada adecuadamente. Utilice herrajes adecuados para el material de las paredes de su casa. Póngase en contacto con su ferretero local que le asesorará en la elección del sistema de tornillos correcto para el tipo de material de la pared.

## EN

### IMPORTANT INFORMATION ABOUT THE ASSEMBLING OF WALL HUNG UNITS

- Once the furniture has been assembled according to the instructions, it's ready to get wall hanged. The furniture can drop down if it hasn't been mounted correctly what can also cause serious material and/ or personal damage. The manufacturer does not assume the responsibility for personal or material damages caused by an incorrect mounting of the wall hung unit.
- Ensure that the wall is resistant enough to carry the weight of the furniture or has been reinforced suitably. Use appropriate hardware for the material of the walls of your house. Contact your local ironmonger who will advise you in choosing the right screw system for the type of material of your wall.

## FR

### INFORMATIONS IMPORTANTES CONCERNANT LE MONTAGE MURAL DU MOBILIER

- Une fois le meuble monté, après avoir suivi les instructions de montage, il s'agit de fixer le meuble au mur en toute sécurité. En cas de montage mural incorrect, le meuble risque de basculer et de tomber par terre; entraînant ainsi de graves dommages matériels et/ou blessures. Le fabricant décline toute responsabilité en cas de blessures ou de dommages matériels pour un accrochage mural incorrect.
- Le mur doit avoir la résistance nécessaire pour la fixation murale. Avant de fixer les meubles au mur il faut impérativement vérifier que le mur possède la résistance requise ou qu'il a été suffisamment renforcé. Le choix de la visserie à utiliser pour la fixation murale utilisée dépend de votre type de mur. Utilisez des fixations adaptées. Contactez votre quincaillier local de confiance pour sélectionner la visserie à utiliser pour la fixation murale.

## PT

### INFORMAÇÕES IMPORTANTES SOBRE A MONTAGEM DOS MOVÉIS NA PAREDE

- Uma vez montado de acordo com as instruções de montagem, o mobiliário está pronto para ser montado na parede. A montagem incorreta na parede pode causar a queda do mobiliário e, portanto, sérios danos materiais e / ou pessoais. O fabricante não se faz responsável por danos pessoais ou materiais causados por uma montagem incorreta na parede.
- A parede deve ter a resistência necessária para a montagem dos móveis na parede, não deve ser montada nas paredes sem primeiro garantir que a parede tem a força necessária ou foi adequadamente reforçada. Use o hardware adequado para o material das paredes da sua casa. Entre em contato com o ferrageiro local, que irá aconselhá-lo a escolher o sistema de parafuso direito para o tipo de material de parede.

## IT

### INFORMAZIONE IMPORTANTE RIGUARDO IL FISSAGGIO ALLA PARETE DEL MOBILE

- Secondo le istruzioni, una volta montato il mobile, sarà pronto per essere fissato alla parete. Un fissaggio alla parete non corretto può ocasionare la caduta del mobile e conseguenti gravi danni materiali e/o a persone. Il produttore non si assume la responsabilità di possibili danni personali o materiali causati da un incorretto fissaggio del mobile alla parete.
- La parete deve avere la resistenza necessaria per sopportare il peso del mobile, non si deve realizzare il fissaggio in una parete senza anteriormente verificare la reale capacità di carico, o se non si è adeguatamente rinforzata per sostenere il peso del mobile. Per il fissaggio, utilizza la ferramenta più adatta al materiale della parete. Nel caso di dubbi, chiedi consiglio al Suo negozio ferramenta di fiducia, sulla scelta delle viti e tasselli più adatti al tipo di materiale della parete.

## DE

### WICHTIGE INFORMATIONEN ZUR MONTAGE VON HÄNGEMÖBELN

- Nach der Montage gemäß der Montageanleitung sind die Möbel bereit für die Befestigung an der Wand. Eine falsche Befestigung kann zum Fall des Möbels führen, was schwerwiegende Material- und / oder Personenschäden zur Folge haben kann. Der Hersteller haftet nicht für Personen- oder Sachschäden, die durch eine inkorrekte Montage an der Wand verursacht wurden.
- Die Wand muss den notwendigen Widerstand für die Montage der Möbel an der Wand haben. Die Möbel sollten nicht an Wände montiert werden, ohne vorher sicherzustellen, dass die Wand die erforderliche Festigkeit hat oder ausreichend verstärkt wurde. Verwenden Sie geeignete Hardware für das Material der Wände Ihres Hauses. Wenden Sie sich an Ihren örtlichen Eisenwarenhändler, der Sie bei der Auswahl des richtigen Schraubensystems für Ihr Wandmaterial berät.

## GR

### ΣΗΜΑΝΤΙΚΕΣ ΠΛΗΡΟΦΟΡΙΕΣ ΣΧΕΤΙΚΑ ΜΕ ΤΗ ΣΤΗΡΙΞΗ ΕΠΙΠΛΩΝ ΣΕ ΤΟΙΧΟ

- Αφού συναρμολογήσετε αυτό το προϊόν σύμφωνα με τις οδηγίες συναρμολόγησης, μπορείτε να το στηρίξετε σε τοίχο. Η εσφαλμένη στήριξη μπορεί να οδηγήσει στην πτώση του προϊόντος από τον τοίχο, προκαλώντας σοβαρές υλικές ζημιές και/ή τραυματισμούς απόρων. Η εταιρεία Ο κατασκευαστής δεν ευθύνεται για προσωπικές ή υλικές βλάβες που προκύπτουν από εσφαλμένη στήριξη.
- Ο τοίχος πρέπει να έχει την απαραίτητη αντίσταση για τη συναρμολόγηση των επίπλων στον τοίχο, η συναρμολόγηση στους τοίχους δεν πρέπει να πραγματοποιείται χωρίς να εξασφαλιστεί πρώτα ότι το τοίχωμα έχει την απαιτούμενη αντοχή ή έχει ενισχυθεί επαρκώς. Χρησιμοποιήστε κατάλληλο υλικό για το υλικό των τοίχων του σπιτιού σας. Επικοινωνήστε με κάποιον ειδικό για τη σωστή επιλογή των βιδών σε σχέση με το υλικό του τοίχου.

## ES

### MONTAJE

- Preparar las piezas que constituyen el mueble.
- Reagrupar y contar el herraje.
- Preparar las herramientas necesarias.
- Preparar la zona de montaje.
- Realizar el montaje sobre una moqueta para evitar rayar el mueble.
- No forzar nunca los ensamblajes.

### USO

- No colocar cerca de fuentes de calor.
- Mueble apto para uso doméstico. Ubicación en el interior de la vivienda.
- Se recomienda, tras la instalación del mueble, airear la habitación donde se encuentre.

### MANTENIMIENTO Y LIMPIEZA

- Limpiar con un paño humedecido con una solución jabonosa.
- Secar con un paño limpio.
- No utilizar paños, trapos o productos de limpieza que puedan rayar la superficie del mueble

## IT

### INSTALLAZIONE

- Prerappare i pezzi che costituiscono il mobile.
- Raggruppare e contare la ferramenta.
- Preparare gli attrezzi necessari.
- Preparare una zona per il montaggio.
- Realizzare il montaggio sopra un tappeto per evitare che il mobile si graffi.
- Non forzare mai l'assemblaggio.

### USO

- Non collocare vicino a fonti di calore.
- Mobile adatto ad un uso domestico. Adatto a uso interno.
- Dopo l'installazione del mobile, si consiglia di arieggiare la stanza.

### ISTRUZIONI PER LA PULIZIA

- Pulire con un panno umido e un detergente neutro.
- Asciugare con un panno pulito.
- Non utilizzare panni, trappi o prodotti di pulizia che possano graffiare la superficie del mobile.

## EN

### ASSEMBLE

- Prepare the different pieces of the furniture.
- Regroup and count the hardware.
- Prepare the necessary tools.
- Prepare the area to assemble to furniture.
- Assemble the furniture on a carpet to avoid any damages.
- Do not force the hardware.

### USE

- Do not place the furniture near the heat sources.
- It's suitable for domestic use, keep it indoors.
- It is recommended, after the assembling to air the room.

### MAINTENANCE AND CLEANING

- Clean it with a damp cloth with mild cleaners.
- Dry it with a clean cloth.
- Do not use cloths or cleaning products that could damage the surface of the furniture.

## DE

### MONTAGEHINWEISE

- Sortieren und identifizieren Sie die Einzelteile.
- Überprüfen Sie die Anzahl der einzelnen Beschlagteile.
- Legen Sie das notwendige Werkzeug bereit.
- Machen Sie einen Montagebereich frei.
- Montieren Sie das Möbelstück auf einem ebenen, weichen und sauberen Untergrund.
- Überziehen Sie die Beschlagteile nicht.

### GEBRAUCHSHINWEISE

- Platzieren Sie das Möbelstück niemals neben Wärmequellen.
- Das Möbelstück ist ausschließlich für den Gebrauch im Haus geeignet.
- Es wird empfohlen, nach dem Aufbau des Möbelstücks, den Raum in dem es sich befindet zu lüften.

### REINIGUNG UND PFLEGE

- Mit einem feuchten Tuch mit milder Seifenlösung abwischen.
- Trocken nachwischen.
- Für die Reinigung verwenden Sie bitte ein weiches Tuch und keinesfalls scharfe oder ätzende Reinigungsmittel.

## FR

### MONTAGE

- Identifier les différents panneaux.
- Regrouper et compter la quincaillerie.
- Munissez-vous de l'outillage nécessaire.
- Aménagez-vous une zone de montage. La moquette ou une couverture protégera des rayures.
- Ne jamais forcer le montage.

### USAGE

- Ne pas placer près des sources de chaleur.
- Meuble apte pour l'usage domestique, on peut le placer à l'intérieur de la maison.
- Il est recommandé, après l'installation du meuble dans son logement, d'aérer fréquemment la pièce concernée.

### ENTRETIEN ET NETTOYAGE

- Nettoyer avec un chiffon humide et une solution savonneuse.
- Essuyer avec un chiffon sec et propre.
- N'utiliser pas de chiffons ou des produits de nettoyage qui puissent rayser la surface du meuble.

## GR

### ΣΥΝΑΡΜΟΛΟΓΗΣΗ

- Προετοιμάστε τα μέρη του επίπλου.
- Ομαδοποιήστε και μετρήστε τα μικρά μέρη (βίδες, μεντεσέδες...).
- Προετοιμάστε τα εργαλεία που θα χρειαστείτε.
- Προετοιμάστε το χώρο συναρμολόγησης.
- Μια μοκέτα θα προφύλασσε από γρατζουνιές.
- Μη ασκείτε πίεση στην εφαρμογή.

### ΧΡΗΣΗ

- Μη το τοποθετείτε κοντά σε πηγή θερμότητας.
- Το έπιπλο έχει κατασκευαστεί για οικιακή χρήση, τοποθετείστε το στο εσωτερικό της οικίας.
- Συνιστάται, μετά τη συναρμολόγηση στον αέρα το δωμάτιο.

### ΣΥΝΤΗΡΗΣΗ ΚΑΙ ΚΑΘΑΡΙΣΜΟΣ

- Καθαρίστε το με ένα πανί μουσκεμένο σε ένα ελαφρύ απορρυπαντικό.
- Στεγνώστε το με ένα καθαρό πανί.
- Μη χρησιμοποιείτε πανιά και καθαριστικά που μπορούν να καταστρέψουν την επιφάνεια.

## PT

### MONTAGEM

- Prepare as peças que compõem o móvel.
- Reagrupe e contar as ferragens.
- Prepare as ferramentas necessárias.
- Prepare a área para a montagem.
- Efectuar a montagem sobre uma alcatifa para evitar arranhar o móvel.
- Não forçar nunca a ensambladura.

### USO

- Não colocar perto de fontes de calor.
- Móvel apto para o uso doméstico. Colocação no interior da vivenda.
- Após a instalação dos móveis, é recomendável ventilar a sala onde está localizado.

### MANUTENÇÃO E LIMPEZA

- Limpe bem com um pano humedecido numa solução detergente suave.
- Seque bem com um pano limpo.
- Não utilizar panos, trapos ou produtos de limpeza que possam riscar a superfície do móvel.

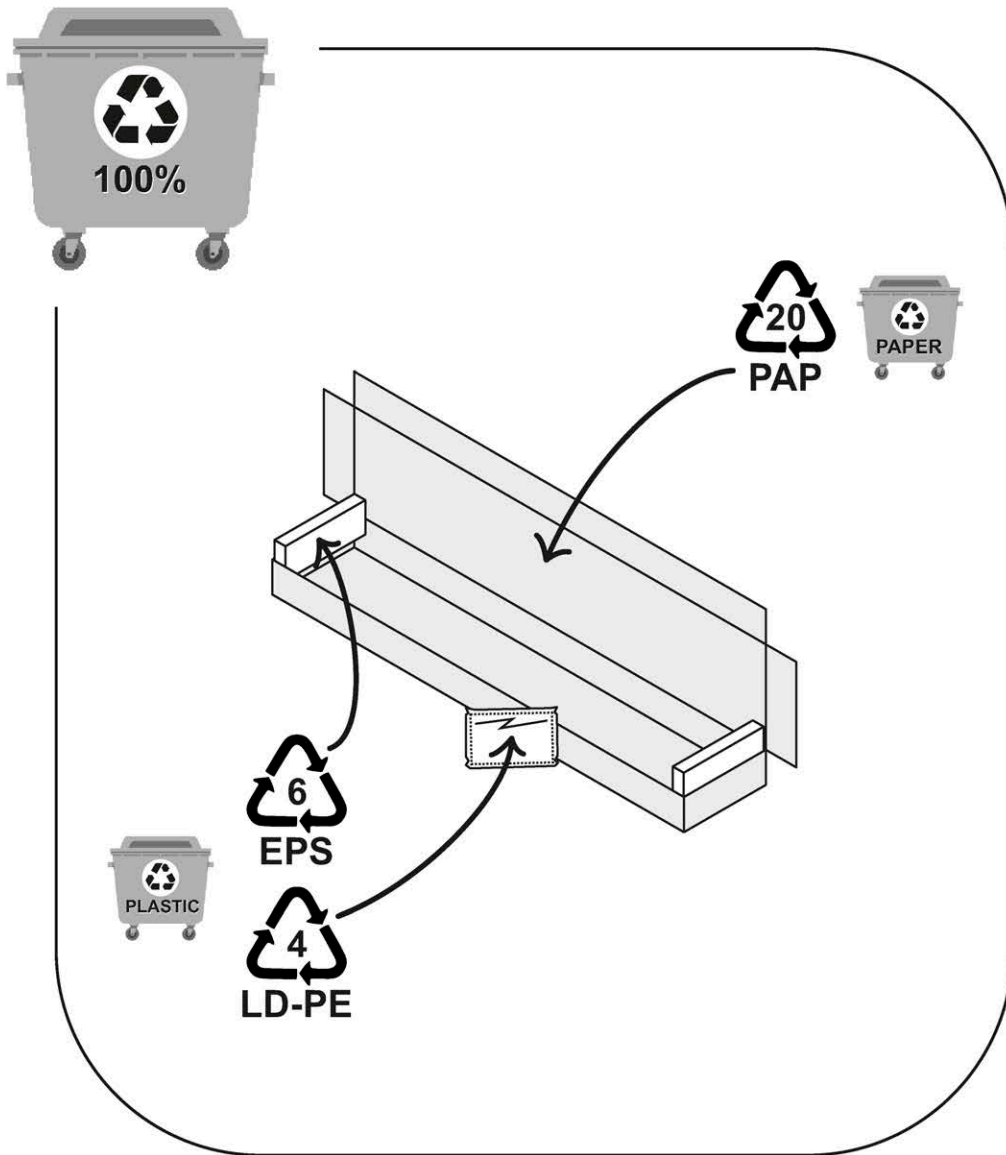

**LE TRI  
+ FACILE**



FR

**Pensez à  
donner ou recycler.**



ou



ou



Association

Magasin

Déchèterie

<https://quefairedemesdechets.fr>